

# Honeywell WEBs

## SECTION 15900 TEMPERATURE CONTROL SYSTEM (TCS) and FACILITY MANAGEMENT CONTROL SYSTEM (FMCS)

**Note to Specifiers: This specification is intended to provide a means to delineate the scope of work between the Division 15 contractor, typically the Temperature Controls Contractor and other divisions supplying products and services that will become part of the overall FMCS. This section must be closely coordinated with Division 16. If other systems are planned for integration, such as lighting, access, fire, etc., please add the appropriate documentation in those sections.**

**This section may also be used to cover the integration of multiple systems supplied by different vendors to facilitate multiple phase bidding and/or multiple site bidding for a single owner. Depending on the type of configuration and specific project requirements, you may delete items of this specification as appropriate.**

### PART 1 GENERAL

#### 1.1 SUMMARY

- A. Furnish all labor, materials, equipment, and service necessary for a complete and operating Temperature Control System (TCS) and Facility Management system (FMCS), utilizing Direct Digital Controls as shown on the drawings and as described herein. Drawings are diagrammatic only.
- B. All labor, material, equipment and software not specifically referred to herein or on the plans, that is required to meet the functional intent of this specification, shall be provided without additional cost to the Owner.
- C. The Owner shall be the named license holder of all software associated with any and all incremental work on the project(s).

#### 1.2 SYSTEM DESCRIPTION

- A. The entire Temperature Control System (TCS) shall be comprised of a network of interoperable, stand-alone digital controllers communicating via LonMark/LonTalk communication protocols to a Network Area Controller (NAC). Temperature Control System products shall be manufactured by Honeywell. Equivalent LonWorks products must be approved in writing by the consulting Engineer and be submitted for approval ten (10) days prior to the date of the bid submittal.

~~A.B.~~ The Facility Management and Control System (FMCS) shall be comprised of Network Area Controller or Controllers (NAC) within each facility. The NAC shall connect to the owner's local or wide area network, depending on configuration. Access to the system, either locally in each building, or remotely from a central site or sites, shall be accomplished through standard Web browsers, via the Internet and/or local area network. Each NAC shall communicate to LonMark/LonTalk (IDC) and/or BACnet (IBC) controllers and other open protocol systems/devices provided under Division 15 or Division 16.

Formatted: Bullets and Numbering

~~B.C.~~ The Facility Management and Control System (FMCS) as provided in this Division shall be based on the Honeywell WEBs System incorporating the Niagara Framework™. Equivalent products must be approved in writing by the consulting Engineer and be submitted for approval ten (10) days prior to the date of the bid submittal. Systems not developed on the Niagara Framework platform are unacceptable.

Formatted: Bullets and Numbering

### 1.3 SUBMITTAL

- A. Eight copies of shop drawings of the components and devices for the entire control system shall be submitted and shall consist of a complete list of equipment and materials, including manufacturers catalog data sheets and installation instructions for all controllers, valves, dampers, sensors, routers, etc. Shop drawings shall also contain complete wiring and schematic diagrams, software descriptions, calculations, and any other details required to demonstrate that the system has been coordinated and will properly function as a system. Terminal identification for all control wiring shall be shown on the shop drawings. A complete written Sequence of Operation shall also be included with the submittal package. Division 16 contractors supplying products and systems, as part of their packages shall provide catalog data sheets, wiring diagrams and point lists to the Division 15 contractor for proper coordination of work.
- B. Submittal shall also include a trunk cable schematic diagram depicting operator workstations, control panel locations and a description of the communication type, media and protocol. Though the Division 15 and 16 contractors shall provide these diagrams for their portions of work, the Systems Integrator shall be responsible for integrating those diagrams into the overall trunk cable schematic diagrams for the entire Wide Area Network (WAN).
- C. Submittal shall also include a complete point list of all points to be connected to the TCS and FMCS. Division 15 and 16 contractors shall provide necessary point lists, protocol documentation, and factory support information for systems provided in their respective divisions but integrated into the FMCS.
- D. Submittal shall also include a copy of each of the graphics developed for the Graphic User Interface including a flowchart (site map) indicating how the graphics are to be linked to one another for system navigation. The graphics are intended to be 80% - 90% complete at this stage with the only remaining changes to be based on review comments from the A/E design team and/or Owner.
- E. Upon completion of the work, provide a complete set of 'as-built' drawings and application software on compact disk. Drawings shall be provided as AutoCAD™ or Visio™ compatible files. Eight copies of the 'as-built' drawings shall be provided in addition to the documents on compact disk. Division 15 and 16 contractors shall provide as-builts for their portions of work. The Division 15 contractor shall be responsible for as-builts pertaining to overall TCS and FMCS architecture and network diagrams. All as built drawings shall also be installed into the FMCS server in a dedicated directory.

### 1.4 SPECIFICATION NOMENCLATURE

- A. Acronyms used in this specification are as follows:

FMCS	Facility Management and Control System
TCS	Temperature Control System
NAC	Network Area Controller
IDC	Interoperable Digital Controller
IBC	Interoperable BACnet Controller
GUI	Graphical User Interface
WBI	Web Browser Interface
POT	Portable Operator's Terminal

PMI	Power Measurement Interface
DDC	Direct Digital Controls
LAN	Local Area Network
WAN	Wide Area Network
OOT	Object Oriented Technology
PICS	Product Interoperability Compliance Statement

1.5 DIVISION OF WORK

- A. The Division 15 and 16 (if applicable) contractors shall be responsible for all controllers (IDC and IBC), control devices, control panels, controller programming, controller programming software, controller input/output and power wiring and controller network wiring.
- B. The Division 15 contractor shall be responsible for the Network Area Controller(s) (NAC), software and programming of the NAC, graphical user interface software (GUI), development of all graphical screens, Web browser pages, setup of schedules, logs and alarms, LonWorks network management and connection of the NAC to the local or wide area network.

1.6 RELATED WORK SPECIFIED ELSEWHERE

~~B.A.~~ Division 16, Electrical:

- 1. Providing motor starters and disconnect switches (unless otherwise noted).
- 2. Power wiring and conduit (unless otherwise noted).

~~4.3.~~ Provision, installation and wiring of smoke detectors (unless otherwise noted).

- 4. Other equipment and wiring as specified in Division 16.

1.7 AGENCY AND CODE APPROVALS

- A. All products of the TCS and FMCS shall be provided with the following agency approvals. Verification that the approvals exist for all submitted products shall be provided with the submittal package. Systems or products not currently offering the following approvals are not acceptable.
  - 1. UL-916; Energy Management Systems
  - 2. C-UL listed to Canadian Standards Association C22.2 No. 205-M1983 “signal Equipment”
  - 3. CE
  - 4. FCC, Part 15, Subpart J, Class A Computing Devices

1.8 SOFTWARE LICENSE AGREEMENT

- A. The Owner shall agree to the manufacturer’s standard software and firmware licensing agreement as a condition of this contract. Such license shall grant use of all programs and application software to Owner as defined by the manufacturer’s license agreement, but shall protect manufacturer’s rights to disclosure of trade secrets contained within such software.
- B. The Owner shall be the named license holder of all software associated with any and all incremental work on the project(s). In addition, the Owner shall receive ownership of all job specific configuration documentation, data files, and application-level software developed for the project. This shall include all custom, job specific software code and documentation for all configuration and programming that is generated for a given project and/or configured for use with the NAC, FMCS Server(s), and any related

Formatted: Bullets and Numbering

Formatted: Bullets and Numbering

LAN / WAN / Intranet and Internet connected routers and devices. Any and all required IDs and passwords for access to any component or software program shall be provided to the owner. The owner shall determine which organizations to be named in the SI organization ID (“orgid”) of all software licenses. Owner shall be free to direct the modification of the “orgid” in any software license, regardless of supplier.

#### 1.9 DELIVERY, STORAGE AND HANDLING

- A. Provide factory-shipping cartons for each piece of equipment and control device. Maintain cartons through shipping, storage, and handling as required to prevent equipment damage. Store equipment and materials inside and protected from weather.

#### 1.10 JOB CONDITIONS

- A. Cooperation with Other Trades: Coordinate the Work of this section with that of other sections to ensure that the Work will be carried out in an orderly fashion. It shall be this Contractor’s responsibility to check the Contract Documents for possible conflicts between his Work and that of other crafts in equipment location, pipe, duct and conduit runs, electrical outlets and fixtures, air diffusers, and structural and architectural features.

### **PART 2 MATERIALS**

#### 2.1 GENERAL

- A. The Temperature Control System (TCS) and Facility Management Control System (FMCS) shall be comprised of a network of interoperable, stand-alone digital controllers, a computer system, graphical user interface software, printers, network devices, valves, dampers, sensors, and other devices as specified herein. All systems and software within FMCS shall be Year 2000 compliant and shall be supported by compliance documentation from the manufacturer.
- B. The installed system shall provide secure password access to all features, functions and data contained in the overall FMCS.

#### 2.2 OPEN, INTEROPERABLE, INTEGRATED ARCHITECTURES

- A. The intent of this specification is to provide a peer-to-peer networked, stand-alone, distributed control system with the capability to integrate ANSI/ASHRAE Standard 135-2001 BACnet, LonWorks technology, MODBUS, OPC, and other open and proprietary communication protocols in one open, interoperable system.
- B. The supplied computer software shall employ object-oriented technology (OOT) for representation of all data and control devices within the system. In addition, adherence to industry standards including ANSI / ASHRAE™ Standard 135-2001, BACnet and LonMark to assure interoperability between all system components is required. For each LonWorks device that does not have LonMark certification, the device supplier must provide an XIF file and a resource file for the device. For each BACnet device, the device supplier must provide a PICS document showing the installed device’s compliance level. Minimum compliance is Level 3; with the ability to support data read and write functionality. Physical connection of BACnet devices shall be via Ethernet (BACnet Ethernet/IP,) and/or RS-485 (BACnet MSTP) as specified.
- C. All components and controllers supplied under this Division shall be true “peer-to-peer” communicating devices. Components or controllers requiring “polling” by a host to pass data shall not be acceptable.

- D. The supplied system must incorporate the ability to access all data using standard Web browsers without requiring proprietary operator interface and configuration programs. An Open DataBase Connectivity (ODBC) or Structured Query Language (SQL) compliant server database is required for all system database parameter storage. This data shall reside on a supplier-installed server for all database access. Systems requiring proprietary database and user interface programs shall not be acceptable.
- E. A hierarchical topology is required to assure reasonable system response times and to manage the flow and sharing of data without unduly burdening the customer's internal Intranet network. Systems employing a "flat" single tiered architecture shall not be acceptable.
  - 1. Maximum acceptable response time from any alarm occurrence (at the point of origin) to the point of annunciation shall not exceed 5 seconds for network connected user interfaces.
  - 2. Maximum acceptable response time from any alarm occurrence (at the point of origin) to the point of annunciation shall not exceed 60 seconds for remote or dial-up connected user interfaces.

**Note to specifiers: There are many possible network configurations. For common Local Area Networks (LAN), use paragraph A. For Wide Area Networks (WAN), specific information about the customer's network configuration will be needed to properly specify equipment and connections required. See the Niagara Specifier's Reference for sample configurations.**

## 2.3 NETWORKS

- A. The Local Area Network (LAN) shall be a 100 Megabits/sec Ethernet network supporting BACnet, Java, XML, HTTP, and SOAP for maximum flexibility for integration of building data with enterprise information systems and providing support for multiple Network Area Controllers (NACs), user workstations and, if specified, a local server.
- B. Local area network minimum physical and media access requirements:
  - 1. Ethernet; IEEE standard 802.3
  - 2. Cable; 100 Base-T, UTP-8 wire, category 5
  - 3. Minimum throughput; 100 Mbps.

## 2.4 NETWORK ACCESS

- A. Remote Access.
  - 1. For Local Area Network installations, provide access to the LAN from a remote location, via the Internet. The Owner shall provide a connection to the Internet to enable this access via high speed cable modem, asynchronous digital subscriber line (ADSL) modem, ISDN line, T1 Line or via the customer's Intranet to a corporate server providing access to an Internet Service Provider (ISP). Customer agrees to pay monthly access charges for connection and ISP.

## 2.5 NETWORK AREA CONTROLLER (NAC)

- A. The Division 17 contractor shall supply one or more Network Area Controllers (NAC) as part of this contract. Number of area controllers required is dependent on the type and quantity of devices provided under Divisions 15 and 16. It is the responsibility of the Division 17 contractor to coordinate with the Division 15 and 16 contractors to determine the quantity and type of devices.

- B. The Network Area Controller (NAC) shall provide the interface between the LAN or WAN and the field control devices, and provide global supervisory control functions over the control devices connected to the NAC. It shall be capable of executing application control programs to provide:
1. Calendar functions
  2. Scheduling
  3. Trending
  4. Alarm monitoring and routing
  5. Time synchronization
  6. Integration of LonWorks controller data and BACnet controller data
  7. Network Management functions for all LonWorks based devices
- C. The Network Area Controller must provide the following hardware features as a minimum:
1. One Ethernet Port – 10/100 Mbps
  2. One RS-232 port
  3. One LonWorks Interface Port – 78KB FTT-10A
  4. One RS-485 ports
  5. Battery Backup
  6. Flash memory for long term data backup (If battery backup or flash memory is not supplied, the controller must contain a hard disk with at least 1 gigabyte storage capacity)
  7. The NAC must be capable of operation over a temperature range of 32 to 122°F
  8. The NAC must be capable of withstanding storage temperatures of between 0 and 158°F
  9. The NAC must be capable of operation over a humidity range of 5 to 95% RH, non-condensing
- D. The NAC shall provide multiple user access to the system and support for ODBC or SQL. A database resident on the NAC shall be an ODBC-compliant database or must provide an ODBC data access mechanism to read and write data stored within it.
- E. The NAC shall support standard Web browser access via the Intranet/Internet. It shall support a minimum of 32 simultaneous users.
- F. Event Alarm Notification and actions
1. The NAC shall provide alarm recognition, storage; routing, management, and analysis to supplement distributed capabilities of equipment or application specific controllers.
  2. The NAC shall be able to route any alarm condition to any defined user location whether connected to a local network or remote via dial-up telephone connection, or wide-area network.
  3. Alarm generation shall be selectable for annunciation type and acknowledgement requirements including but limited to:
    - a. To alarm
    - b. Return to normal
    - c. To fault

4. Provide for the creation of a minimum of eight of alarm classes for the purpose of routing types and or classes of alarms, i.e.: security, HVAC, Fire, etc.
  5. Provide timed (schedule) routing of alarms by class, object, group, or node.
  6. Provide alarm generation from binary object “runtime” and /or event counts for equipment maintenance. The user shall be able to reset runtime or event count values with appropriate password control.
- G. Control equipment and network failures shall be treated as alarms and annunciated.
- H. Alarms shall be annunciated in any of the following manners as defined by the user:
1. Screen message text
  2. Email of the complete alarm message to multiple recipients. Provide the ability to route and email alarms based on:
    - a. Day of week
    - b. Time of day
    - c. Recipient
  3. Pagers via paging services that initiate a page on receipt of email message
  4. Graphic with flashing alarm object(s)
  5. Printed message, routed directly to a dedicated alarm printer
- I. The following shall be recorded by the NAC for each alarm (at a minimum):
1. Time and date
  2. Location (building, floor, zone, office number, etc.)
  3. Equipment (air handler #, accessway, etc.)
  4. Acknowledge time, date, and user who issued acknowledgement.
  5. Number of occurrences since last acknowledgement.
- J. Alarm actions may be initiated by user defined programmable objects created for that purpose.
- K. Defined users shall be given proper access to acknowledge any alarm, or specific types or classes of alarms defined by the user.
- L. A log of all alarms shall be maintained by the NAC and/or a server (if configured in the system) and shall be available for review by the user.
- M. Provide a “query” feature to allow review of specific alarms by user defined parameters.
- N. A separate log for system alerts (controller failures, network failures, etc.) shall be provided and available for review by the user.
- O. An Error Log to record invalid property changes or commands shall be provided and available for review by the user.

## 2.6 Data Collection and Storage

- A. The NAC shall have the ability to collect data for any property of any object and store this data for future use.
- B. The data collection shall be performed by log objects, resident in the NAC that shall have, at a minimum, the following configurable properties:

1. Designating the log as interval or deviation.
  2. For interval logs, the object shall be configured for time of day, day of week and the sample collection interval.
  3. For deviation logs, the object shall be configured for the deviation of a variable to a fixed value. This value, when reached, will initiate logging of the object.
  4. For all logs, provide the ability to set the maximum number of data stores for the log and to set whether the log will stop collecting when full, or rollover the data on a first-in, first-out basis.
  5. Each log shall have the ability to have its data cleared on a time-based event or by a user-defined event or action.
- C. All log data shall be stored in a relational database in the NAC and the data shall be accessed from a server (if the system is so configured) or a standard Web browser.
- D. All log data, when accessed from a server, shall be capable of being manipulated using standard SQL statements.
- E. All log data shall be available to the user in the following data formats:
1. HTML
  2. XML
  3. Plain Text
  4. Comma or tab separated values
- F. Systems that do not provide log data in HTML and XML formats at a minimum shall not be acceptable.
- G. The NAC shall have the ability to archive its log data either locally (to itself), or remotely to a server or other NAC on the network. Provide the ability to configure the following archiving properties, at a minimum:
1. Archive on time of day
  2. Archive on user-defined number of data stores in the log (buffer size)
  3. Archive when log has reached its user-defined capacity of data stores
  4. Provide ability to clear logs once archived

## 2.7 AUDIT LOG

- A. Provide and maintain an Audit Log that tracks all activities performed on the NAC. Provide the ability to specify a buffer size for the log and the ability to archive log based on time or when the log has reached its user-defined buffer size. Provide the ability to archive the log locally (to the NAC), to another NAC on the network, or to a server. For each log entry, provide the following data:
1. Time and date
  2. User ID
  3. Change or activity: i.e., Change setpoint, add or delete objects, commands, etc.

## 2.8 DATABASE BACKUP AND STORAGE

- A. The NAC shall have the ability to automatically backup its database. The database shall be backed up based on a user-defined time interval.
- B. Copies of the current database and, at the most recently saved database shall be stored in the NAC. The age of the most recently saved database is dependent on the user-defined database save interval.

- C. The NAC database shall be stored, at a minimum, in XML format to allow for user viewing and editing, if desired. Other formats are acceptable as well, as long as XML format is supported.

**Note to specifiers: See Appendix A for specific control sequences for each unitary controller required for this installation. Insert desired control sequences where needed in the Interoperable digital controller section.**

#### 2.9 INTEROPERABLE DIGITAL CONTROLLER (IDC)

- A. Controls shall be Honeywell Excel 10 microprocessor based Interoperable LonWorks Controllers (IDC) or approved equal. Where possible, all Interoperable Digital Controllers shall bear the applicable LonMark™ interoperability logo on each product delivered.
- B. HVAC control shall be accomplished using LonMark™ based devices where the application has a LonMark profile defined. Where LonMark devices are not available for a particular application, devices based on LonWorks shall be acceptable. For each LonWorks device that does not have LonMark certification, the device supplier must provide an XIF file for the device. Publicly available specifications for the Applications Programming Interface (API) must be provided for each LonWorks / LonMark controller defining the programming or setup of each device. The Division 15 contractor shall provide all programming, documentation and programming tools necessary to set up and configure the supplied devices per the specified sequences of operation.
- C. The Division 15 contractor shall run the LonWorks network trunk to the nearest Network Area Controller (NAC). Coordinate locations of the NAC to ensure that maximum network wiring distances, as specified by the LonWorks wiring guidelines, are not exceeded. A maximum of 126 devices may occupy any one LonWorks trunk and must be installed using the appropriate trunk termination device. All LonWorks and LonMark devices must be supplied using FTT-10A LonWorks communications transceivers.
- D. The Network Area Controller (NAC) will provide all scheduling, alarming, trending, and network management for the LonMark / LonWorks based devices.
- E. The IDCs shall communicate with the NAC at a baud rate of not less than 78.8K baud. The IDC shall provide LED indication of communication and controller performance to the technician, without cover removal.
- F. All IDCs shall be fully application programmable and shall at all times maintain their LONMARK certification, if so certified. Controllers offering application selection only (non-programmable), require a 10% spare point capacity to be provided for all applications. All control sequences within or programmed into the IDC shall be stored in non-volatile memory, which is not dependent upon the presence of a battery, to be retained.
- G. The Division 15 contractor supplying the IDC's shall provide documentation for each device, with the following information at a minimum:
  - 1. Network Variable Inputs (nvi's); name and type
  - 2. Network Variable Outputs (nvo's); name and type
  - 3. Network configuration parameters (nci, nco); name and type
- H. It is the responsibility of the Division 15 contractor to ensure that the proper Network Variable Inputs and Outputs (nvi and nvo) are provided in each IDC, as required by the point charts.
- I. The supplier of any programmable IDC shall provide one copy of the manufacturer's programming tool, with documentation, to the owner.

**Note to specifiers: Depending on the project configuration and requirements, a Graphical User Interface (GUI) software application can be specified. If this is desired, use Item 2.9. Alternatively, the user interface software can be a standard Web browser (WBI) such as Microsoft Internet Explorer or Netscape Navigator. If this is the desired method, use Item 2.10. You can also specify a configuration where both the Graphical User Interface Software and Web browsers are used to interface with the system. If this is the case, use both Items 2.9 and 2.10.**

## 2.9.2.10 GRAPHICAL USER INTERFACE SOFTWARE

### A. Operating System:

1. The GUI shall run on Microsoft Windows XP Professional.

### B. The GUI shall employ browser-like functionality for ease of navigation. It shall include a tree view (similar to Windows Explorer) for quick viewing of, and access to, the hierarchical structure of the database. In addition, menu-pull downs, and toolbars shall employ buttons, commands and navigation to permit the operator to perform tasks with a minimum knowledge of the HVAC Control System and basic computing skills. These shall include, but are not limited to, forward/backward buttons, home button, and a context sensitive locator line (similar to a URL line), that displays the location and the selected object identification.

### C. Real-Time Displays. The GUI, shall at a minimum, support the following graphical features and functions:

1. Graphic screens shall be developed using any drawing package capable of generating a GIF, BMP, or JPG file format. Use of proprietary graphic file formats shall not be acceptable. In addition to, or in lieu of a graphic background, the GUI shall support the use of scanned pictures.
2. Graphic screens shall have the capability to contain objects for text, real-time values, animation, color spectrum objects, logs, graphs, HTML or XML document links, schedule objects, hyperlinks to other URL's, and links to other graphic screens.
3. Graphics shall support layering and each graphic object shall be configurable for assignment to a layer. A minimum of six layers shall be supported.
4. Modifying common application objects, such as schedules, calendars, and set points shall be accomplished in a graphical manner.
  - a. Schedule times will be adjusted using a graphical slider, without requiring any keyboard entry from the operator.
  - b. Holidays shall be set by using a graphical calendar without requiring any keyboard entry from the operator.
5. Commands to start and stop binary objects shall be done by right-clicking the selected object and selecting the appropriate command from the pop-up menu. No entry of text shall be required.
6. Adjustments to analog objects, such as set points, shall be done by right-clicking the selected object and using a graphical slider to adjust the value. No entry of text shall be required.

### D. System Configuration. At a minimum, the GUI shall permit the operator to perform the following tasks, with proper password access:

- a. Create, delete or modify control strategies.
- b. Add/delete objects to the system.

Formatted: Bullets and Numbering

- c. Tune control loops through the adjustment of control loop parameters.
  - d. Enable or disable control strategies.
  - e. Generate hard copy records or control strategies on a printer.
  - f. Select points to be alarmable and define the alarm state.
  - g. Select points to be trended over a period of time and initiate the recording of values automatically.
- E. On-Line Help. Provide a context sensitive, on-line help system to assist the operator in operation and editing of the system. On-line help shall be available for all applications and shall provide the relevant data for that particular screen. Additional help information shall be available through the use of hypertext. All system documentation and help files shall be in HTML format.
- F. Security. Each operator shall be required to log on to that system with a user name and password in order to view, edit, add, or delete data. System security shall be selectable for each operator. The system administrator shall have the ability to set passwords and security levels for all other operators. Each operator password shall be able to restrict the operators' access for viewing and/or changing each system application, full screen editor, and object. Each operator shall automatically be logged off of the system if no keyboard or mouse activity is detected. This auto log-off time shall be set per operator password. All system security data shall be stored in an encrypted format.
- G. System Diagnostics. The system shall automatically monitor the operation of all workstations, printers, modems, network connections, building management panels, and controllers. The failure of any device shall be annunciated to the operator.
- H. Alarm Console
1. The system will be provided with a dedicated alarm window or console. This window will notify the operator of an alarm condition, and allow the operator to view details of the alarm and acknowledge the alarm. The use of the Alarm Console can be enabled or disabled by the system administrator.
  2. When the Alarm Console is enabled, a separate alarm notification window will supercede all other windows on the desktop and shall not be capable of being minimized or closed by the operator. This window will notify the operator of new alarms and un-acknowledged alarms. Alarm notification windows or banners that can be minimized or closed by the operator shall not be acceptable.

#### 2-102.11 WEB BROWSER CLIENTS

- A. The system shall be capable of supporting an unlimited number of clients using a standard Web browser such as Internet Explorer™ or Netscape Navigator™. Systems requiring additional software (to enable a standard Web browser) to be resident on the client machine, or manufacture-specific browsers shall not be acceptable.
- B. The Web browser software shall run on any operating system and system configuration that is supported by the Web browser. Systems that require specific machine requirements in terms of processor speed, memory, etc., in order to allow the Web browser to function with the FMCS, shall not be acceptable.
- C. The Web browser shall provide the same view of the system, in terms of graphics, schedules, calendars, logs, etc., and provide the same interface methodology as is provided by the Graphical User Interface. Systems that require different views or that require different means of interacting with objects such as schedules, or logs, shall not be permitted.
- D. The Web browser client shall support at a minimum, the following functions:

Formatted: Bullets and Numbering

1. User log-on identification and password shall be required. If an unauthorized user attempts access, a blank web page shall be displayed. Security using Java authentication and encryption techniques to prevent unauthorized access shall be implemented.
2. Graphical screens developed for the GUI shall be the same screens used for the Web browser client. Any animated graphical objects supported by the GUI shall be supported by the Web browser interface.
3. HTML programming shall not be required to display system graphics or data on a Web page. HTML editing of the Web page shall be allowed if the user desires a specific look or format.
4. Storage of the graphical screens shall be in the Network Area Controller (NAC), without requiring any graphics to be stored on the client machine. Systems that require graphics storage on each client are not acceptable.
5. Real-time values displayed on a Web page shall update automatically without requiring a manual “refresh” of the Web page.
6. Users shall have administrator-defined access privileges. Depending on the access privileges assigned, the user shall be able to perform the following:
  - a. Modify common application objects, such as schedules, calendars, and set points in a graphical manner.
    1. Schedule times will be adjusted using a graphical slider, without requiring any keyboard entry from the operator.
    2. Holidays shall be set by using a graphical calendar, without requiring any keyboard entry from the operator.
  - b. Commands to start and stop binary objects shall be done by right-clicking the selected object and selecting the appropriate command from the pop-up menu. No entry of text shall be required.
  - c. View logs and charts
  - d. View and acknowledge alarms
  - e. Setup and execute SQL queries on log and archive information
7. The system shall provide the capability to specify a user’s (as determined by the log-on user identification) home page. Provide the ability to limit a specific user to just their defined home page. From the home page, links to other views, or pages in the system shall be possible, if allowed by the system administrator.
8. Graphic screens on the Web Browser client shall support hypertext links to other locations on the Internet or on Intranet sites, by specifying the Uniform Resource Locator (URL) for the desired link.

***Note to specifiers: Depending on the project configuration and requirements, a central server may be desired. Typically a server is used on projects where there are multiple Network Area Controllers (NAC) connected locally over a LAN, or remotely over a WAN. The server provides time synchronization, file archiving, and other features for overall system administration. If this is desired, use Item 2.11. See the Niagara Specifier’s Reference for sample configurations.***

## 2.11.2.12 SERVER FUNCTIONS AND HARDWARE

- A. A central server, located (in, at) \_\_\_\_\_, shall be provided. The server shall support all Network Area Controllers (NAC) connected to the customer's network whether local or remote.
- B. Local connections shall be via an Ethernet LAN. Remote connections can be via ISDN, ADSL, T1 or dial-up connection.
- C. It shall be possible to provide access to all Network Area Controllers via a single connection to the server. In this configuration, each Network Area Controller can be accessed from a remote Graphical User Interface (GUI) or from a standard Web browser (WBI) by connecting to the server.
- D. The server shall provide the following functions, at a minimum:
  - 1. Global Data Access: The server shall provide complete access to distributed data defined anywhere in the system.
  - 2. Distributed Control: The server shall provide the ability to execute global control strategies based on control and data objects in any NAC in the network, local or remote.
  - 3. The server shall include a master clock service for its subsystems and provide time synchronization for all Network Area Controllers (NAC).
  - 4. The server shall accept time synchronization messages from trusted precision Atomic Clock Internet sites and update its master clock based on this data.
  - 5. The server shall provide scheduling for all Network Area Controllers and their underlying field control devices.
  - 6. The server shall provide demand limiting that operates across all Network Area Controllers. The server must be capable of multiple demand programs for sites with multiple meters and or multiple sources of energy. Each demand program shall be capable of supporting separate demand shed lists for effective demand control.
  - 7. The server shall implement the BACnet Command Prioritization scheme (16 levels) for safe and effective contention resolution of all commands issued to Network Area Controllers. Systems not employing this prioritization shall not be accepted.
  - 8. Each Network Area Controller supported by the server shall have the ability to archive its log data, alarm data and database to the server, automatically. Archiving options shall be user-defined including archive time and archive frequency.
  - 9. The server shall provide central alarm management for all Network Area Controllers supported by the server. Alarm management shall include:
    - 1. Routing of alarms to display, printer, email and pagers
    - 2. View and acknowledge alarms
    - 3. Query alarm logs based on user-defined parameters
  - 10. The server shall provide central management of log data for all Network Area Controllers supported by the server. Log data shall include process logs, runtime and event counter logs, audit logs and error logs. Log data management shall include:
    - 1. Viewing and printing log data
    - 2. Exporting log data to other software applications
    - 3. Query log data based on user-defined parameters
- E. Server Hardware Requirements: The server hardware platform shall have the following requirements:

Formatted: Bullets and Numbering

1. The computer shall be an Intel Pentium M based computer (minimum processing speed of 2.4 GHz with 1 GB RAM and a 100-gigabyte minimum hard drive). It shall include a DVD-ROM/CD-RW Combination Drive, 2-parallel ports, 2-asynchronous serial ports and 2-USB ports. A minimum 17" flat panel color monitor, 1280 x 1024 optimal preset resolution, 25 ms response time shall also be included.
2. The server operating system shall be Microsoft Windows XP Professional. Include Microsoft Internet Explorer 6.0 or later.
3. Connection to the FMCS network shall be via an Ethernet network interface card, 100 Mbps.
4. A system printer shall be provided. Printer shall be laser type with a minimum 600 x 600-dpi resolution and rated for 60-PPM print speed minimum.
5. For dedicated alarm printing, provide a dot matrix printer, either 80 or 132 column width. The printer shall have a parallel port interface.

#### 2-122.13 SYSTEM PROGRAMMING

- A. The Graphical User Interface software (GUI) shall provide the ability to perform system programming and graphic display engineering as part of a complete software package. Access to the programming functions and features of the GUI shall be through password access as assigned by the system administrator.
- B. A library of control, application, and graphic objects shall be provided to enable the creation of all applications and user interface screens. Applications are to be created by selecting the desired control objects from the library, dragging or pasting them on the screen, and linking them together using a built in graphical connection tool. Completed applications may be stored in the library for future use. Graphical User Interface screens shall be created in the same fashion. Data for the user displays is obtained by graphically linking the user display objects to the application objects to provide "real-time" data updates. Any real-time data value or object property may be connected to display its current value on a user display. Systems requiring separate software tools or processes to create applications and user interface displays shall not be acceptable.
- C. Programming Methods
  1. Provide the capability to copy objects from the supplied libraries, or from a user-defined library to the user's application. Objects shall be linked by a graphical linking scheme by dragging a link from one object to another. Object links will support one-to-one, many-to-one, or one-to-many relationships. Linked objects shall maintain their connections to other objects regardless of where they are positioned on the page and shall show link identification for links to objects on other pages for easy identification. Links will vary in color depending on the type of link; i.e., internal, external, hardware, etc.
  2. Configuration of each object will be done through the object's property sheet using fill-in the blank fields, list boxes, and selection buttons. Use of custom programming, scripting language, or a manufacturer-specific procedural language for configuration will not be accepted.
  3. The software shall provide the ability to view the logic in a monitor mode. When on-line, the monitor mode shall provide the ability to view the logic in real time for easy diagnosis of the logic execution. When off-line (debug), the monitor mode shall allow the user to set values to inputs and monitor the logic for diagnosing execution before it is applied to the system.
  4. All programming shall be done in real-time. Systems requiring the uploading, editing, and downloading of database objects shall not be allowed.

Formatted: Bullets and Numbering

5. The system shall support object duplication within a customer's database. An application, once configured, can be copied and pasted for easy re-use and duplication. All links, other than to the hardware, shall be maintained during duplication.

**Note to specifiers: If LonWorks devices are included as part of the project, it is necessary to provide LonWorks network management tools to manage the devices. Include Item 2.13 if LonWorks devices are included in the project.**

#### 2.132.14 LonWorks NETWORK MANAGEMENT

- A. The Graphical User Interface software (GUI) shall provide a complete set of integrated LonWorks network management tools for working with LonWorks networks. These tools shall manage a database for all LonWorks devices by type and revision, and shall provide a software mechanism for identifying each device on the network. These tools shall also be capable of defining network data connections between LonWorks devices, known as "binding". Systems requiring the use of third party LonWorks network management tools shall not be accepted.
- B. Network management shall include the following services: device identification, device installation, device configuration, device diagnostics, device maintenance and network variable binding.
- C. The network configuration tool shall also provide diagnostics to identify devices on the network, to reset devices, and to view health and status counters within devices.
- D. These tools shall provide the ability to "learn" an existing LonWorks network, regardless of what network management tool(s) were used to install the existing network, so that existing LonWorks devices and newly added devices are part of a single network management database.
- E. The network management database shall be resident in the Network Area Controller (NAC), ensuring that anyone with proper authorization has access to the network management database at all times. Systems employing network management databases that are not resident, at all times, within the control system, shall not be accepted.

Formatted: Bullets and Numbering

#### 2.142.15 OBJECT LIBRARIES

- A. A standard library of objects shall be included for development and setup of application logic, user interface displays, system services, and communication networks.
- B. The objects in this library shall be capable of being copied and pasted into the user's database and shall be organized according to their function. In addition, the user shall have the capability to group objects created in their application and store the new instances of these objects in a user-defined library.
- C. In addition to the standard libraries specified here, the supplier of the system shall maintain an on-line accessible (over the Internet) library, available to all registered users to provide new or updated objects and applications as they are developed.
- D. All control objects shall conform to the control objects specified in the BACnet specification.
- E. The library shall include applications or objects for the following functions, at a minimum:
  1. Scheduling Object. The schedule must conform to the schedule object as defined in the BACnet specification, providing 7-day plus holiday & temporary scheduling features and a minimum of 10 on/off events per day. Data entry to be by graphical sliders to speed creation and selection of on-off events.
  2. Calendar Object. . The calendar must conform to the calendar object as defined in the BACnet specification, providing 12-month calendar features to allow for holiday or special event data

Formatted: Bullets and Numbering

entry. Data entry to be by graphical “point-and-click” selection. This object must be “linkable” to any or all scheduling objects for effective event control.

3. Duty Cycling Object. Provide a universal duty cycle object to allow repetitive on/off time control of equipment as an energy conserving measure. Any number of these objects may be created to control equipment at varying intervals
  4. Temperature Override Object. Provide a temperature override object that is capable of overriding equipment turned off by other energy saving programs (scheduling, duty cycling etc.) to maintain occupant comfort or for equipment freeze protection.
  5. Start-Stop Time Optimization Object. Provide a start-stop time optimization object to provide the capability of starting equipment just early enough to bring space conditions to desired conditions by the scheduled occupancy time. Also, allow equipment to be stopped before the scheduled un-occupancy time just far enough ahead to take advantage of the building’s “flywheel” effect for energy savings. Provide automatic tuning of all start / stop time object properties based on the previous day’s performance.
  6. Demand Limiting Object. Provide a comprehensive demand-limiting object that is capable of controlling demand for any selected energy utility (electric, oil, and gas). The object shall provide the capability of monitoring a demand value and predicting (by use of a sliding window prediction algorithm) the demand at the end of the user defined interval period (1-60 minutes). This object shall also accommodate a utility meter time sync pulse for fixed interval demand control. Upon a prediction that will exceed the user defined demand limit (supply a minimum of 6 per day), the demand limiting object shall issue shed commands to either turn off user specified loads or modify equipment set points to effect the desired energy reduction. If the list of sheddable equipment is not enough to reduce the demand to below the set point, a message shall be displayed on the users screen (as an alarm) instructing the user to take manual actions to maintain the desired demand. The shed lists are specified by the user and shall be selectable to be shed in either a fixed or rotating order to control which equipment is shed the most often. Upon suitable reductions in demand, the demand-limiting object shall restore the equipment that was shed in the reverse order in which it was shed. Each sheddable object shall have a minimum and maximum shed time property to effect both equipment protection and occupant comfort.
- F. The library shall include control objects for the following functions. All control objects shall conform to the objects as specified in the BACnet specification.
1. Analog Input Object - Minimum requirement is to comply with the BACnet standard for data sharing. Allow high, low and failure limits to be assigned for alarming. Also, provide a time delay filter property to prevent nuisance alarms caused by temporary excursions above or below the user defined alarm limits.
  2. Analog Output Object - Minimum requirement is to comply with the BACnet standard for data sharing.
  3. Binary Input Object - Minimum requirement is to comply with the BACnet standard for data sharing. The user must be able to specify either input condition for alarming. This object must also include the capability to record equipment run-time by counting the amount of time the hardware input is in an “on” condition. The user must be able to specify either input condition as the “on” condition.
  4. Binary Output Object - Minimum requirement is to comply with the BACnet standard for data sharing. Properties to enable minimum on and off times for equipment protection as well as interstart delay must be provided. The BACnet Command Prioritization priority scheme shall be incorporated to allow multiple control applications to execute commands on this object with the

highest priority command being invoked. Provide sixteen levels of priority as a minimum. Systems not employing the BACnet method of contention resolution shall not be acceptable.

5. PID Control Loop Object - Minimum requirement is to comply with the BACnet standard for data sharing. Each individual property must be adjustable as well as to be disabled to allow proportional control only, or proportional with integral control, as well as proportional, integral and derivative control.
  6. Comparison Object - Allow a minimum of two analog objects to be compared to select either the highest, lowest, or equality between the two linked inputs. Also, allow limits to be applied to the output value for alarm generation.
  7. Math Object - Allow a minimum of four analog objects to be tested for the minimum or maximum, or the sum, difference, or average of linked objects. Also, allow limits to be applied to the output value for alarm generation.
  8. Custom Programming Objects - Provide a blank object template for the creation of new custom objects to meet specific user application requirements. This object must provide a simple BASIC-like programming language that is used to define object behavior. Provide a library of functions including math and logic functions, string manipulation, and e-mail as a minimum. Also, provide a comprehensive on-line debug tool to allow complete testing of the new object. Allow new objects to be stored in the library for re-use.
  9. Interlock Object - Provide an interlock object that provides a means of coordination of objects within a piece of equipment such as an Air Handler or other similar types of equipment. An example is to link the return fan to the supply fan such that when the supply fan is started, the return fan object is also started automatically without the user having to issue separate commands or to link each object to a schedule object. In addition, the control loops, damper objects, and alarm monitoring (such as return air, supply air, and mixed air temperature objects) will be inhibited from alarming during a user-defined period after startup to allow for stabilization. When the air handler is stopped, the interlocked return fan is also stopped, the outside air damper is closed, and other related objects within the air handler unit are inhibited from alarming thereby eliminating nuisance alarms during the off period.
  10. Temperature Override Object - Provide an object whose purpose is to provide the capability of overriding a binary output to an "On" state in the event a user specified high or low limit value is exceeded. This object is to be linked to the desired binary output object as well as to an analog object for temperature monitoring, to cause the override to be enabled. This object will execute a Start command at the Temperature Override level of start/stop command priority unless changed by the user.
  11. Composite Object - Provide a container object that allows a collection of objects representing an application to be encapsulated to protect the application from tampering, or to more easily represent large applications. This object must have the ability to allow the user to select the appropriate parameters of the "contained" application that are represented on the graphical shell of this container.
- G. The object library shall include objects to support the integration of devices connected to the Network Area Controller (NAC). At a minimum, provide the following as part of the standard library included with the programming software:
1. LonMark/LonWorks devices. These devices shall include, but not be limited to, devices for control of HVAC, lighting, access, and metering. Provide LonMark manufacturer-specific objects to facilitate simple integration of these devices. All network variables defined in the LonMark

profile shall be supported. Information (type and function) regarding network variables not defined in the LonMark profile shall be provided by the device manufacturer.

2. For devices not conforming to the LonMark standard, provide a dynamic object that can be assigned to the device based on network variable information provided by the device manufacturer. Device manufacturer shall provide an XIF file, resource file and documentation for the device to facilitate device integration.
3. For BACnet devices, provide the following objects at a minimum:
  - a. Analog In
  - b. Analog Out
  - c. Analog Value
  - d. Binary
  - e. Binary In
  - f. Binary Out
  - g. Binary Value
  - h. Multi-State In
  - i. Multi-State Out
  - j. Multi-State Value
  - k. Schedule Export
  - l. Calendar Export
  - m. Trend Export
  - n. Device
4. For each BACnet object, provide the ability to assign the object a BACnet device and object instance number.
5. For BACnet devices, provide the following support at a minimum
  - a. Segmentation
  - b. Segmented Request
  - c. Segmented Response
  - d. Application Services
  - e. Read Property
  - f. Read Property Multiple
  - g. Write Property
  - h. Write Property Multiple
  - i. Confirmed Event Notification
  - j. Unconfirmed Event Notification
  - k. Acknowledge Alarm

- l. Get Alarm Summary
- m. Who-has
- n. I-have
- o. Who-is
- p. I-am
- q. Subscribe COV
- r. Confirmed COV notification
- s. Unconfirmed COV notification
- t. Media Types
- u. Ethernet
- v. BACnet IP Annex J
- w. MSTP
- x. BACnet Broadcast Management Device (BBMD) function
- y. Routing

**Note to specifiers: Depending on the project configuration and requirements, it may be desired to integrate data from devices that are not LonMark or BACnet. These could include industrial or plant floor devices such as PLC's. Because of the many drivers available, a common method of providing this integration, is Dynamic Data Exchange (DDE). If this is desired, use Item 2.15.**

#### ~~2-15~~2.16 DDE DEVICE INTEGRATION

- A. The Network Area Controller shall support the integration of device data via Dynamic Data Exchange (DDE), over the Ethernet Network. The Network Area Controller shall act as a DDE client to another software application that functions as a DDE server.
- B. Provide the required objects in the library, included with the Graphical User Interface programming software, to support the integration of these devices into the FMCS. Objects provided shall include at a minimum:
  - 1. DDE Generic AI Object
  - 2. DDE Generic AO Object
  - 3. DDE Generic BO Object
  - 4. DDE Generic BI Object

Formatted: Bullets and Numbering

#### ~~2-16~~2.17 MODBUS SYSTEM INTEGRATION

- A. The Network Area Controller shall support the integration of device data from Modbus RTU, Ascii, or TCP control system devices. The connection to the Modbus system shall be via an RS-232, RS485, or Ethernet IP as required by the device.
- B. Provide the required objects in the library, included with the Graphical User Interface programming software, to support the integration of the Modbus system data into the FPMS. Objects provided shall include at a minimum:
  - 1. Read/Write Modbus AI Registers
  - 2. Read/Write Modbus AO Registers

Formatted: Bullets and Numbering

3. Read/Write Modbus BI Registers
  4. Read/Write Modbus BO Registers
- C. All scheduling, alarming, logging and global supervisory control functions, of the Modbus system devices, shall be performed by the Network Area Controller.
- D. The FMCS supplier shall provide a Modbus system communications driver. The equipment system vendor that provided the equipment utilizing Modbus shall provide documentation of the system's Modbus interface and shall provide factory support at no charge during system commissioning

#### 2.17~~2.18~~ OPC SYSTEM INTEGRATION

- A. The Network Area Controller shall act as an OPC client and shall support the integration of device data from OPC servers. The connection to the OPC server shall be Ethernet IP as required by the device. The OPC client shall support third party OPC servers compatible with the Data Access 1.0 and 2.0 specifications.
- B. Provide the required objects in the library, included with the Graphical User Interface programming software, to support the integration of the OPC system data into the BAS. Objects provided shall include at a minimum:
1. Read/Write OPC AI Object
  2. Read/Write OPC AO Object
  3. Read/Write OPC BI Object
  4. Read/Write OPC BO Object
  5. Read/Write OPC Date/Time Input Object
  6. Read/Write OPC Date/Time Output Object
  7. Read/Write OPC String Input Object
  8. Read/Write OPC String Output Object
- C. All scheduling, alarming, logging and global supervisory control functions, of the OPC system devices, shall be performed by the Network Area Controller.
- D. The FMCS supplier shall provide an OPC client communications driver. The equipment system vendor that provided the equipment utilizing OPC shall provide documentation of the system's OPC server interface and shall provide factory support at no charge during system commissioning.

**Note to specifiers: Depending on the project configuration and requirements, the customer may wish to supply their own computers (PC's), or they may be provided as part of the specification. In addition, portable computers may be required depending on the configuration or how the customer wants to access their system. Items 2.17 and 2.18 pertain to computer requirements for the Graphical User Interface Software (GUI). If no GUI software is specified, a standard Web browser can provide the customer's access to the system. In this case, you may use these hardware requirements, or let the customer's Web browser requirements dictate the hardware requirements.**

#### 2.19 GRAPHICAL USER INTERFACE COMPUTER HARDWARE (DESKTOP)

- A. The browser workstation shall be an Intel Pentium based computer (minimum processing speed of 2.4 Ghz with 1.0 GB RAM and a 100-gigabyte minimum hard drive). It shall include a DVD-ROM/CD-

Formatted: Bullets and Numbering

RW Combination Drive, 2-parallel ports, 2-asynchronous serial ports and 2-USB ports. A minimum 17" flat panel color monitor, 1280 x 1024 optimal preset resolution, 25 ms response time, shall also be included.

- B. Connection to the FMCS network shall be via an Ethernet network interface card, 10 Mbps.
- C. A system printer shall be provided. Printer shall be laser type with a minimum 600 x 600-dpi resolution and rated for 8 PPM print speed minimum.

#### 2.20 GRAPHICAL USER INTERFACE COMPUTER HARDWARE (LAPTOP COMPUTER)

- A. The laptop computer shall consist of an Intel Pentium based laptop computer (minimum processing speed of 2 Ghz with 1 GB RAM and a 80-gigabyte minimum hard drive). It shall include a CD-ROM drive, a 3.5" floppy drive.
- B. Connection to the FMCS network shall be via an Ethernet network interface card, 10/100 Mbps.
- C. A system printer shall be provided. Printer shall be laser type with a minimum 600 x 600-dpi resolution and rated for 60 PPM print speed minimum.

#### 2.3 OTHER CONTROL SYSTEM HARDWARE

- A. Temperature Control Air Compressor (when required): A duplex air compressor system (two compressors mounted on one tank) shall be furnished and installed by the temperature control contractor.
  - 1. Air compressor system shall be sized to fit the pneumatic control system, to insure no more than 33% run time.
  - 2. The tank shall be sized for a maximum of 6 starts per hour
  - 3. An automatic alternator shall be connected to the motors and pressure switches, in a 'lead-lag' manner, and shall alternate compressor operation after each on-off cycle. Alternator shall be further connected to energize the 'lag' operation after each on-off cycle. Alternator shall be further connected to energize the 'lag' compressor at the setting of the lower pressure switch if the "lead" compressor fails or is disabled for service.
  - 4. Air compressor system shall include a refrigerated air dryer sized for the capacity of the air compressor.
  - 5. Accessories such as filters, pressure regulators, valves, spring isolators, automatic tank drain etc. shall also be furnished for a complete operating system.
- B. Space Temperature Wall Module. Wall Module shall be Honeywell or equivalent.
  - 1. Wall module shall have a 20K Ohm NTC thermistor temperature sensor with operating range of 45 to 99 F under a locking cover/enclosure with UL 916 listing designed for mounting on a standard electrical switch box.
  - 2. Space temperature sensors shall be accurate to plus or minus one F degree.
  - 3. Where specified, space temperature sensors shall have a setpoint knob calibrated for warmer-cooler adjustments (*option: calibrated to allow plus or minus adjustments to a software setpoint*).
  - 4. Where specified, wall module shall also have an after-hours override pushbutton and LED override indicator.

5. Where specified, the wall module shall have a fan coil unit fan control switch for (*auto-off-on*)(*auto-off-low-med-hi*) fan control. The wall module function is further specified in SECTION III Sequence of Operation.

3.C. Standard Automatic Control Dampers. Dampers shall be Honeywell or equivalent. Provide all automatic control dampers not specified to be integral with other equipment.

1. Frames shall be 5 inches wide and of no less than 16-gauge galvanized steel. Inter-blade linkage shall be within the frame and out of the air stream.
2. Blades shall not be over 8 inches wide nor less than 16-gauge galvanized steel triple V type for rigidity.
3. Bearings shall be acetyl, oilite, nylon or ball-bearing with ½ inch diameter plated steel shafts.
4. Dampers shall be suitable for temperature ranges of -40 to 180F.
5. All proportional control dampers shall be opposed or parallel blade type as hereinafter specified and all two-position dampers shall be parallel blade types.
6. Dampers shall be sized to meet flow requirements of the application. The sheet metal contractor shall furnish and install baffles to fit the damper to duct size. Baffles shall not exceed 6". Dampers with dimensions of 24 inches and less shall be rated for 3,000 fpm velocity and shall withstand a maximum system pressure of 5.0 in. w.c. Dampers with dimensions of 36 inches and less shall be rated for 2,500 fpm velocity and shall withstand a maximum system pressure of 4.0 in. w.c. Dampers with dimensions of 48 inches and less shall be rated for 2,000 fpm velocity and shall withstand a maximum system pressure of 2.5 in. wc. Damper blade width shall be no greater than 8 inches, and dampers over 48 inches wide by 74 inches high shall be sectionalized.
7. Maximum leakage for dampers in excess of sixteen inches square shall be 30 CFM per square foot at static pressure of 1 inch of WC. Testing and ratings to be in accordance with AMCA Standard 500.

4.D. Low Leakage Automatic Control Dampers. Dampers shall be Honeywell or equivalent. Provide all automatic control dampers not specified to be integral with other equipment.

1. Frames shall be 5 inches wide and of no less than 16-gauge galvanized steel. Inter-blade linkage shall be within the frame and out of the air stream.
2. Blades shall not be over 8 inches wide nor less than 16-gauge galvanized steel triple V type for rigidity.
3. Bearings shall be acetyl, oilite, nylon or ball-bearing with ½ inch diameter plated steel shafts.
4. Dampers shall be suitable for temperature ranges of -40 to 180F.
5. All proportional control dampers shall be opposed or parallel blade type as hereinafter specified and all two-position dampers shall be parallel blade types.
6. Dampers shall be sized to meet flow requirements of the application. The sheet metal contractor shall furnish and install baffles to fit the damper to duct size. Baffles shall not exceed 6". Dampers with dimensions of 24 inches and less shall be rated for 3,000 fpm velocity and shall withstand a maximum system pressure of 5.0 in. w.c. Dampers with dimensions of 36 inches and less shall be rated for 2,500 fpm velocity and shall withstand a maximum system pressure of 4.0 in. wc. Dampers with dimensions of 48 inches and less shall be rated for 2,000 fpm velocity and shall withstand a maximum system pressure of 2.5 in. w.c.
7. Side seals shall be stainless steel of the tight-seal spring type.

Formatted: Bullets and Numbering

Formatted: Bullets and Numbering

8. Dampers shall be minimum leakage type to conserve energy and the temperature control manufacturer shall submit leakage data for all low leakage control dampers with the temperature control submittal.
  9. Maximum leakage for low leakage dampers in excess of sixteen inches square shall be 8 CFM per square foot at static pressure of 1 inch of WC.
  10. Low leakage damper blade edges shall be fitted with replaceable, snap-on, inflatable seals to limit damper leakage.
  11. Testing and ratings shall be in accordance with AMCA Standard 500.
  12. Damper blade width shall be no greater than 8 inches, and dampers over 48 inches wide by 74 inches high shall be sectionalized. Testing and ratings to be in accordance with AMCA Standard 500.
- E. Round Motorized Dampers. Dampers shall be Honeywell or equivalent. Round dampers shall be provided where specified and shall be factory mounted in a section of round duct a minimum of 12 inches long, but no less than one inch longer than the duct diameter.
1. Duct shall be sleeve type spiral duct crimped on the downstream end, 24 gage galvanized minimum except duct over 12 inches in diameter shall be 22 gage.
  2. Duct shall have an integral galvanized steel actuator mounting plate and a ½ inch zinc-coated steel blade shaft extending a minimum of 2 inches beyond the actuator mounting plate.
  3. Shaft bearings shall be flanged bronze oilite pressed into the frame.
  4. The blade shall be a minimum 16 gage galvanized steel, and damper frame shall be provided with closed-cell neoprene seals with silicone rubber bead. Damper shall be designed for a 2500 ft/min approach velocity and a 4 inch minimum static pressure.
  5. Damper shall be suitable for operation from 32 to 130F temperatures.
  6. Damper and actuator combination shall be designed for leakage rates less than 13 cfm per square foot at one inch w.c differential and 25 cfm at four inches w.c. Actuator shall have an external declutch lever to allow manual blade positioning during equipment and power malfunctions.
- F. Control Valves: (*Globe Type*) Valves shall be Honeywell or equivalent. Control valves shall be 2-way or 3-way pattern as shown constructed for tight shutoff and shall operate satisfactory against system pressures and differentials.
1. Two-position valves shall be 'line' size. Proportional control valves shall be sized for a maximum pressure drop of 5.0 psi at rated flow (except as may be noted on the drawings).
  2. Two-way water valves shall have equal percentage flow characteristics and three-way valves shall have equal percentage flow characteristics straight through and linear through the bypass.
  3. Provide valve position indicator on all valves. Leakage rate shall be no more than 0.05% of Cv.
  4. Valves 1/2 inch through 1 1/2 inch shall be screwed pattern except where solder connections are specified for valves 1/2 or 3/4 inches.
  5. Three-way valves bypass port shall be of one size reduced Cv to preclude the need for a bypass port balancing valve.
  6. Valve and cartridge replacement tool shall be configured for maintenance or replacement without draining the coil to prevent water spill; however, an integral isolation valve on the control valve outlet will also be acceptable.
  7. Valves shall close off against 58 psi minimum.

8. Two inch valves shall be “screwed” configuration and 2-1/2 inch and larger valves shall be “flanged” configuration and ANSI-rated to withstand the pressures and temperatures encountered.
  9. Valves shall have stainless-steel stems and spring loaded Teflon packaging with replaceable discs.
- G. Control Valves: (**Characterized Ball Valves**) Valves shall be Honeywell or equivalent. Control valves 1/2 to 2 inches shall be 2-way or 3-way forged brass screwed pattern as shown constructed for tight shutoff and shall operate satisfactory against system pressures and differentials.
1. Two-position valves shall be ‘line’ size. Proportional control valves shall be sized for a maximum pressure drop of 5.0 psi at rated flow (except as may be noted on the drawings).
  2. Two-way water valves shall have equal percentage flow characteristics and three-way valves shall have equal percentage flow characteristics straight through and linear flow through the bypass.
  3. Leakage rate shall be ANSI Class IV (no more than 0.01% of Cv).
  4. Valves shall be rated for no less than 350 psig at no less than 250 degrees F.
  5. Provide a removable handle to operate valves manually during actuator power loss or failure.
  6. Two-way valves shall close off against 100 psi minimum, and three-way valves shall close off against 40 psi minimum.
  7. Valves shall have stainless-steel or chemically nickel-plated brass stem and throttling port.
  8. Valves shall be tagged with Cv rating and model number.
- H. Butterfly Control Valves: Valves shall be Honeywell or equivalent. Where specified butterfly control valves over 2” in size shall be cast iron body type for 2-way or 3-way applications specified constructed for tight shutoff and shall operate satisfactory against system pressures and differentials.
1. Valves shall have tapped lugs for standard flange connection, and designed for isolation and removal of downstream piping at full rated pressure.
  2. Two-position valves shall be ‘line’ size.
  3. Proportional control valves shall be sized for a maximum pressure drop of 5.0 psi at rated flow (except as may be noted on the drawings).
  4. Valves shall be rated for bubble tight shutoff at no less than 150 psi.
  5. Valve disc shall be aluminum bronze.
  6. Valve stems shall be stainless steel, with inboard top and bottom bronze bearings, and an external corrosion resistant top bearing to absorb actuator side thrust.
- I. Duct Mount, Pipe Mount and Outside Air Temperature Sensors: Temperature sensors with an accuracy of  $\pm 0.3^{\circ}$  F. Temperature sensors shall be Honeywell or equivalent.
1. Outside air sensors shall include an integral sun shield.
  2. Duct sensors shall have sensor approximately in center of the duct, and shall have selectable lengths of 6, 12, and 18 inches.
  3. Multipoint averaging element sensors shall be provided where specified and shall have a minimum of one foot of sensor length for each square foot of duct area (provide multiple sensors if necessary).
  4. Pipe mount sensors shall have copper, or stainless steel separable wells.
- J. Current Sensitive Switches: Solid state, split core current switch that operates when the current level (sensed by the internal current transformer) exceeds the adjustable trip point shall be provided where

specified. Current switches shall include an integral LED for indication of trip condition and a current level below trip set point.

- K. Water Flow Meters: Water flow meters shall be axial turbine style flow meters which translate liquid motion into electronic output signals proportional to the flow sensed.
  - 1. Flow sensing turbine rotors shall be non-metallic and not impaired by magnetic drag.
  - 2. Flow meters shall be 'insertion' type complete with 'hot-tap' isolation valves to enable sensor removal without water supply system shutdown.
  - 3. Accuracy shall be  $\pm 2\%$  of actual reading from 0.4 to 20 feet per second flow velocities.
- L. Low Temperature Limit Switches. Limit switches shall be Honeywell or equivalent. Safety low limit shall be manual reset twenty foot limited fill type responsive to the coolest section of its length.
- M. High Temperature Limit Switches. Limit and Safety switches shall be Honeywell or equivalent. Safety high limit (firestats) shall be manual reset type.
- N. CO2 Sensors. CO2 sensors shall be Honeywell or equivalent.
  - 1. Carbon Dioxide sensors shall be 0-10 Vdc analog output type, with corrosion free gold-plated non-dispersive infrared sensing, designed for duct mounting.
  - 2. Sensor shall incorporate internal diagnostics for power, sensor, analog and output checking, and automatic background calibration algorithm for reduced maintenance. Sensor range shall be 0-2000 PPM with  $\pm 50$  PPM accuracy.
- O. Humidity Sensors. Humidity sensors shall be Honeywell or equivalent.
  - 1. Duct and room sensors shall have a sensing range of 5% to 95%.
  - 2. Duct sensors shall be provided with a sampling chamber.
  - 3. Outdoor air humidity sensors shall have a sensing range of 20% to 95% RH. They shall have a compensated ambient temperature range of  $-40^{\circ}\text{F}$  to  $170^{\circ}\text{F}$ .
- P. Enthalpy Sensors. Enthalpy sensors shall be Honeywell or equivalent. Duct mounted enthalpy sensor shall include a temperature sensor and a humidity sensor constructed to close an electrical contact upon a drop in enthalpy (total heat) to enable economizer modes of operation where specified.

*(OPTION - C7400 – Select one)* Where specified provide duct mounted sensor including solid state temperature and humidity sensors with electronics which shall output a 4-20 ma signal input to the controller upon a varying enthalpy (total heat) to enable economizer modes of operation when outside air enthalpy is suitable for free cooling .
- Q. Annular Pitot Tube Flow Meter. Annular pitot tube shall be averaging type differential pressure sensors with four total head pressure ports and one static port made of austenitic stainless steel.
  - 1. Sensor shall have an accuracy of  $\pm .25\%$  of full flow and a repeatability of  $\pm .05\%$  of measured value.
  - 2. Transmitter shall be electronic and shall produce a linear output of 4 to 20 mAdc corresponding to the required flow span.
  - 3. The transmitter shall include noninteracting zero and span adjustments.
  - 4. Acceptable Manufacturers: Pitot Tube: Dieterich Annubar, Transmitter: Setra or Dieterich
- R. Variable Frequency Drives. Variable Frequency drives shall be Honeywell or equivalent.

1. Variable frequency drives shall be UL listed and sized for the power and loads applied.
2. Drives shall include built-in radio frequency interference (RFI) filters and be constructed to operate in equipment rooms and shall not be susceptible to electromagnetic disturbances typically encountered in such environments. Similarly, the drives must not excessively disturb the environment within which it is used.
3. All VFDs over 3 horsepower shall be provided with an AC choke.
4. VFDs shall be installed in strict conformance to the manufacturer's installation instructions, and shall be rated to operate over a temperature range of 14 to 104 F.
5. VFD automatic operation shall be suitable for an analog input signal compatible with the digital controller output.
6. Each VFD shall be fan cooled and have an integral keypad and alphanumeric display unit for user interface. The display shall indicate VFD status (RUN motor rotation, READY, STOP, ALARM, and FAULT), and shall indicate the VFD current control source (DDC input signal, keypad, or field bus control). In addition to the alphanumeric display, the display unit shall have three pilot lights to annunciate when the power is on (green), when the drive is running (green, blinks when stopping and ramping down), and when the drive was shut down due to a detected fault (red, fault condition presented on the alphanumeric display).
7. Three types of faults shall be monitored, "FAULT" shall shut the motor down, "FAULT Auto-reset" shall shut the motor down and try to restart it for a programmable number of tries, and "FAULT Trip" shall shut the motor down after a FAULT Auto-reset fails to restart the motor. Coded faults shall be automatically displayed for the following faults:

- Over current
- Over voltage
- Earth ground
- Emergency stop
- System (component failure)
- Under voltage
- Phase missing
- Heat sink under temperature
- Heat sink over temperature
- Motor stalled
- Motor over temperature
- Motor underload
- Cooling fan failure
- Inverter bridge over temperature
- Analog input control under current
- Keypad failure
- Other product unique monitored conditions

8. In addition to annunciating faults, at the time of fault occurrence the VFD shall capture and make available to the user certain system data for subsequent analysis during fault trouble shooting, including duration of operation (days, hours, minutes, seconds), output frequency, motor current, motor voltage, motor power, motor torque, DC voltage, unit temperature, run status, rotation direction, and any warnings. The last 30 fault occurrences shall be retained as well as the fault data listed in the previous sentence of each fault. New faults beyond 30 shall overwrite the oldest faults.

9. The display unit keypad shall allow setting operational parameters including minimum and maximum frequency, and acceleration and deceleration times. The display shall offer user monitoring of frequency, unit temperature, motor speed, current, torque, power, voltage, and temperature.
- S. **Actuators, General.** Actuators shall be Honeywell or equivalent. All automatically controlled devices, unless specified otherwise elsewhere, shall be provided with actuators sized to operate their appropriate loads with sufficient reserve power to provide smooth modulating action or two-position action and tight close-off. Valves shall be provided with actuators suitable for floating or analog signal control as required to match the controller output. Actuators shall be power failure return type where valves or dampers are required to fail to a safe position and where specified.
- T. Non-Spring Return Low Torque Direct Coupled 35 & 70 lb-in Actuators. Actuators shall be Honeywell or equivalent. Actuators shall be 35 (ML 6161 or ML 7161) or 70 lb-in. (ML6174 or ML 7174) with strokes adjustable for 45, 60, or 90 degree rotation applications and designed for operation between 20 and 125 F.
1. Each actuator shall also have a minimum position adjustable rotation of 0 to 30 degrees.
  2. Actuators shall be for floating or two position (ML 6161 or ML6174) control, or for 4-20 mA or 2-10Vdc (ML7161 or ML7174) input signals.
  3. Analog control actuators shall have a cover mounted direct/reverse acting switch.
  4. Actuator motor shall be magnetically coupled or shall have limit switch stops to disengage power at the ends of the stroke.
  5. Actuators shall be direct connected (no linkages) and provided with a manual declutch for manual positioning.
  6. Actuators shall have NEMA 1 environmental protection rating and be 24 volt and UL listed with UL94-5V plenum requirement compliance.
  7. Minimum design life of actuators shall be for 1,500,000 repositions and 35 lb-in. models shall be designed for 50,000 open-close cycles and 70 lb-in. models shall be designed for 40,000 open-close cycles.
  8. Actuator options shall include 1) Auxiliary feedback potentiometers, 2) open-closed indicator switches, 3) actuator timings of 90 seconds, 3 minutes, or 7 minutes, one or two auxiliary switches, and 4) torque of 35 or 70 lb-in.
- U. Non-Spring Return High Torque 177 and 300 lb-in Actuators. MN6120A, MN6134A, MN7234A Series Actuators shall be UL listed 24 Vac in NEMA 2 enclosures designed for operation between -5 and 140 F.
1. Rotation direction shall be switch selectable.
  2. Minimum design life of actuators shall be for 1,500,000 repositions and for 60,000 open-close cycles.
  3. Actuators shall be suitable for the controller output signals encountered, floating or analog, and shall have full cycle timing of 95 seconds.
  4. Actuators shall be direct connected (no linkages) and provided with a manual declutch for manual positioning.
- (Select one or more of the following descriptions required)*
- Actuators shall have 300 lb-in. torque.

- Actuators shall have 177 lb-in. torque with adjustable stroke, 30 to 90 degrees.
  - Actuators shall have 177 lb-in. torque with adjustable stroke, 30 to 90 degrees, and shall auxiliary end switches to annunciate full open and full closed positions.
- V. Spring Return Direct Coupled Actuators. Actuators shall have torque ratings of 44lb-in. (MS4105, MS7505, MS8105), 88 lb-in. (MS4110, MS7510, MS 8110), or 175 lb-in (MS4120, MS7520, MS8120). Actuators shall be Honeywell or equivalent. Actuators shall be modulating 90 seconds nominal timing or two-position 45 seconds nominal timing types with strokes for 90 degree rotation applications and designed for operation between -40 and 140 F.
1. Each torque rating group shall have optionally selected control types, floating control, 2-position 24 Vac, 2-position line voltage, or analog input which is switch selectable as 0-10Vdc, 10-0 Vdc, 2-10 Vdc, or 10-2 Vdc.
  2. Actuator spring return direction (open or closed) shall be easily reversed in the field, and actuators shall spring return in no greater than 20 seconds.
  3. Actuators shall be direct connected (no linkages), and shall have integral position indication.
  4. Actuators shall have NEMA 2 environmental protection rating, and UL approved and plenum rated per UL873.
  5. Minimum design life of modulating actuators shall be for 1,500,000 repositions and 60,000 spring returns, except 2-position actuators shall be for 50,000 spring returns.
  6. Each actuator shall be provided with a manual power-off positioning lever for manual positioning during power loss or system malfunctions, including a gear-train lock to prevent spring action.
  7. Upon power restoration after gear lock, normal operation shall automatically recur.
- W. Fast Acting Two Position Fire & Smoke Actuators (ML4115, ML8115). Actuators shall be Honeywell or equivalent. Fire/smoke damper actuators shall be direct connected (no linkages) two-position spring return types with stroke for 90 degree nominal rotation applications and designed for 60,000 full stroke cycles and normal operation between 0 and 130 F.
1. Actuators control shall be compatible with SPST control switch and with torque ratings of 30 lb-in.
  2. Actuator timing shall be 25 seconds maximum in powered instances and shall spring-return in 15 seconds.
  3. Actuators shall be UL listed with UL873 plenum rating with die-cast aluminum housing with integral junction box and conduit knockouts, and designed to operate reliably in smoke control systems requiring UL555S ratings up to 350F.
  4. The actuator shall be designed to operate for 30 minutes during a one-time excursion to 350F.
  5. Actuator shall require no special cycling during long-term holding, and shall “hold” with no audible noise at a power consumption of approximately half of the driving power.
  6. Actuators shall be 24 volt (ML8115) or 120 volt (ML4115) with models for clockwise (add a B suffix) and counter-clockwise (add an A suffix) spring return.

**NOTE to specifier: ML4115 spec above is good for MSXX20F also except MSXX20 is designed for 175 lb-in torque, rated for 30,000 cycles, has 15 second open & spring return timing, and has optional end switches to annunciate when the ACTUATOR is open and closed.**

- X. Temperature Control Panels: Furnish temperature control panels of code gauge steel with locking doors for mounting all devices as shown. Control panels shall meet all requirements of Title 24, California Administrative Code. All electrical devices within a control panel shall be factory wired. All external wiring shall be connected to terminal strips mounted within the panel. Provide engraved phenolic nameplates identifying all devices mounted on the face of control panels. A complete set of 'as-built' control drawings (relating to the controls within that panel) shall be furnished within each control panel.

***Note to specifiers: Specifications for project execution can be inserted here. Items covered should include installation, training, documentation, warranty, acceptance testing and, if desired, system commissioning.***

### **PART 3 EXECUTION**

#### **3.1 INSTALLATION**

- A. All work described in this section shall be performed by system integrators or contractors that have a successful history in the design and installation of integrated control systems. The installing office shall have a minimum of five years of integration experience and shall provide documentation in the submittal package verifying the company's experience.
- B. Install system and materials in accordance with manufacturer's instructions, and as detailed on the project drawing set.
- C. Drawings of the TCS and FMCS network are diagrammatic only and any apparatus not shown, but required to make the system operative to the complete satisfaction of the Architect shall be furnished and installed without additional cost.
- D. Line and low voltage electrical connections to control equipment shown specified or shown on the control diagrams shall be furnished and installed by this contractor in accordance with these specifications.
- E. Equipment furnished by the HVAC Contractor that is normally wired before installation shall be furnished completely wired. Control wiring normally performed in the field will be furnished and installed by this contractor.

#### **3.2 WIRING**

- A. All electrical control wiring and power wiring to the control panels, NAC, computers and network components shall be the responsibility of the this contractor.
- B. The electrical contractor (Div. 16) shall furnish all power wiring to electrical starters and motors.
- C. All wiring shall be in accordance with the Project Electrical Specifications (Division 16), the National Electrical Code and any applicable local codes. All FMCS wiring shall be installed in the conduit types specified in the Project Electrical Specifications (Division 16) unless otherwise allowed by the National Electrical Code or applicable local codes. Where FMCS plenum rated cable wiring is allowed it shall be run parallel to or at right angles to the structure, properly supported and installed in a neat and workmanlike manner.

#### **3.3 WARRANTY**

- A. Equipment, materials and workmanship incorporated into the work shall be warranted for a period of one year from the time of system acceptance.
- B. Within this period, upon notice by the Owner, any defects in the work provided under this section due to faulty materials, methods of installation or workmanship shall be promptly (within 48 hours after receipt of notice) repaired or replaced by this contractor at no expense to the Owner

#### 3.4 WARRANTY ACCESS

- A. The Owner shall grant to this contractor, reasonable access to the TCS and FMCS during the warranty period.
- B. The owner shall allow the contractor to access the TCS and FMCS from a remote location for the purpose of diagnostics and troubleshooting, via the Internet, during the warranty period.

#### 3.5 SOFTWARE LICENSE

- A. The Owner shall be the named license holder of all software associated with any and all incremental work on the project(s). The owner, or his appointed agent, shall determine which organizations to be named in the “**orgid**” of all Niagara Framework software licenses.
- B. The owner, or his appointed agent, shall be free to direct the modification of the “**orgid**” in any Niagara Framework software license, regardless of supplier.
- C. The owner, or his appointed agent, shall receive ownership of all job specific software configuration documentation, data files, and application-level software developed for the project. This shall include all custom, job specific software code and documentation for all configuration and programming that is generated for a given project and /or configured for use within Niagara Framework (Niagara) based controllers and/or servers and any related LAN / WAN / Intranet and Internet connected routers and devices. Any and all required Ids and passwords for access to any component or software program shall be provided to the owner.

#### 3.6 ACCEPTANCE TESTING

- A. Upon completion of the installation, this contractor shall load all system software and start-up the system. This contractor shall perform all necessary calibration, testing and de-bugging and perform all required operational checks to insure that the system is functioning in full accordance with these specifications.
- B. This contractor shall perform tests to verify proper performance of components, routines, and points. Repeat tests until proper performance results. This testing shall include a point-by-point log to validate 100% of the input and output points of the DDC system operation.
- C. Upon completion of the performance tests described above, repeat these tests, point by point as described in the validation log above in presence of Owner's Representative, as required. Properly schedule these tests so testing is complete at a time directed by the Owner's Representative. Do not delay tests so as to prevent delay of occupancy permits or building occupancy.
- D. System Acceptance: Satisfactory completion is when this contractor and the Division 16 contractor have performed successfully all the required testing to show performance compliance with the requirements of the Contract Documents to the satisfaction of the Owner's Representative. System acceptance shall be contingent upon completion and review of all corrected deficiencies.

#### 3.7 OPERATOR INSTRUCTION, TRAINING

- A. During system commissioning and at such time acceptable performance of the TCS and FMCS hardware and software has been established this contractor shall provide on-site operator instruction to the owner's operating personnel. Operator instruction shall be done during normal working hours and shall be performed by a competent representative familiar with the system hardware, software and accessories.
- B. This contractor shall provide 40 hours of instruction to the owner's designated personnel on the operation of the TCS and FMCS and describe its intended use with respect to the programmed functions specified. Operator orientation of the systems shall include, but not be limited to; the overall operation program, equipment functions (both individually and as part of the total integrated system), commands,

systems generation, advisories, and appropriate operator intervention required in responding to the System's operation.

C. The training shall be in three sessions as follows:

1. Initial Training: One day session (8 hours) after system is started up and at least one week before first acceptance test. Manual shall have been submitted at least two weeks prior to training so that the owners' personnel can start to familiarize themselves with the system before classroom instruction begins.
2. First Follow-Up Training: Two days (16 hours total) approximately two weeks after initial training, and before Formal Acceptance. These sessions will deal with more advanced topics and answer questions.
3. Warranty Follow Up: Two days (16 hours total) in no less than 4 hour increments, to be scheduled at the request of the owner during the one year warranty period. These sessions shall cover topics as requested by the owner such as; how to add additional points, create and gather data for trends, graphic screen generation or modification of control routines.

D.

## **PART 4 SEQUENCES OF OPERATION**

### **4.1 SUMMARY**

- A. This contractor shall coordinate control functions, such as scheduling and supervisory-level global control, points list, and control sequences needed for this installation as listed below. Contractor shall provide written documentation to archive the system operation as accepted by the owner.

***Note to specifiers: This part is designed to provide a clear understanding of what points are to be provided in the user interface and what they must be able to do. For each building system to be included list the points and the actions the Graphical User Interface and/or the Web browser interface must support. Each table represents a single system. In each table, enter the name of the system, the points desired, and place an "X" in the column indicating the required functionality.***

## **PART 5 POINT LISTS**

### **5.1 SUMMARY**

- A. The points in the following table shall be accessible from the Graphical User Interface (GUI) and/or the Web browser interface (WBI). The supplier of the IDC and IBC devices shall ensure that the points listed in this table are accessible on their respective networks, by the Network Area Controller (NAC).

B. The following abbreviations apply to the point table to indicate what level of functionality must be provided:

1. D = Display only
2. M = Modify value
3. A = Alarm
4. L = Log
5. S = Schedule
6. GC = Global supervisory control routine such as demand limiting

System						
Point	D	M	A	L	S	GC

END OF SECTION

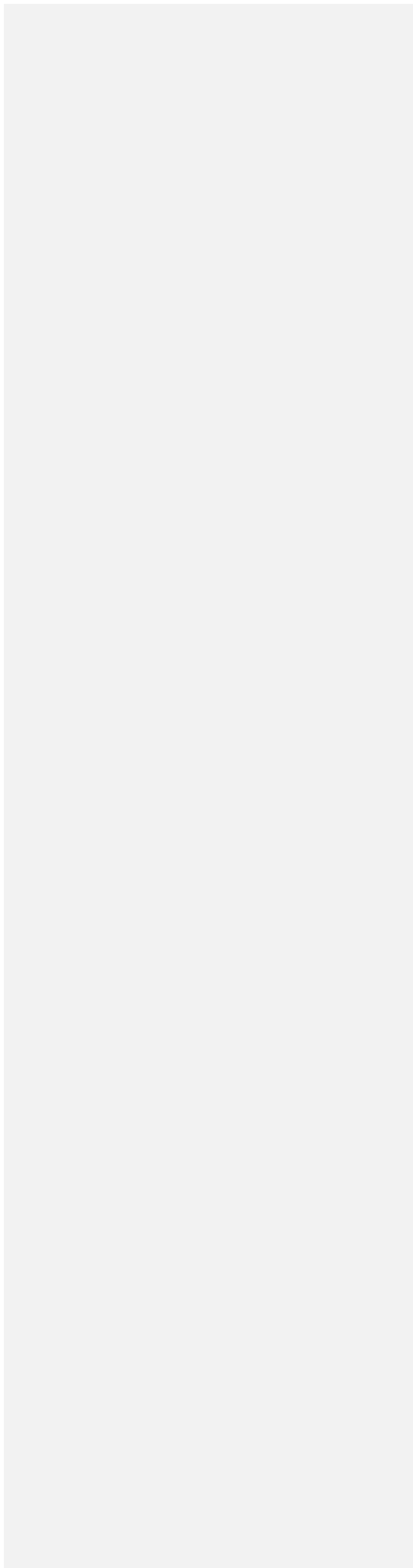

## Appendix A. Sequences of Operation

Select and edit the appropriate sequences, or develop new sequences and paste them into the Sequence of Operation in SECTION III. The following sequences should be carefully reviewed to assure that they fit the project systems and objectives.

- A. Constant Volume Air Handling Unit, 2-Stage Cooling, 2-Stage Heating, with Economizer Enabled from Outside Air Dry Bulb Temperature.

Constant Volume HVAC Unit Controller Software. The constant volume unit controller shall be configurable for air handlers with staged or analog heating and cooling, minimum or modulating economizer outside or mixing damper dampers, and enthalpy or dry bulb economizer changeover. Controller shall comply with LonMark HVAC profile #8030.

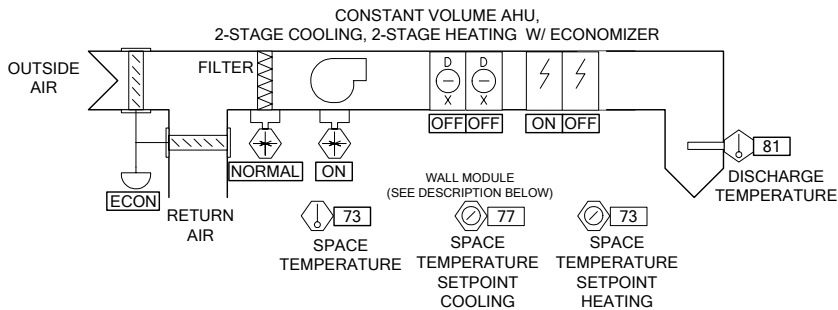

1. Fan Off. Anytime the fan is off, all system heating and cooling shall be off, and the mixing dampers shall be positioned closed to the outside air.
2. Fan and Mode Control. System fan and heating/cooling temperature setpoints shall normally be placed in the occupied, standby, or unoccupied mode of operation and control via a system scheduler unique seven day schedule. Prior to scheduled occupied periods, the unoccupied temperature setpoint shall be ramped up to the occupied setpoint over a time period proportional to the temperature difference between the room temperature and the occupied temperature setpoint such that at occupancy time the occupied temperature is reached. During unoccupied and standby periods the outside air damper shall be closed and the fan shall remain off until heating or cooling is demanded to satisfy the unoccupied and standby temperature setpoints. The standby mode of operation is for periods of temporary vacancy such as the lunch hour, and shall use owner determined temperature setpoints a degree or two away from the occupied comfort settings.

System shall automatically revert to the proper mode of operation after restoration of power after a power failure. Units shall restart at a random staggered time interval after power restoration.

3. Occupant Schedule Override Control. When any room HVAC system is operating in a mode other than OCCUPIED, each room temperature sensor wall module schedule override button shall provide the room occupant with ability to place the system in the occupied mode of operation for 60 (180 default, user programmable) minutes by pressing the module override button. Via the

button, the occupant shall also have the ability to cancel the override command, or to place the system in the unoccupied mode when operating in the occupied mode. Via the module LED, the occupant shall have the ability to note the status of the system overrides as being in the override mode, override unoccupied mode, continuously occupied mode via a network command, or in the normal mode of operation (LED off).

4. Smoke Control. The operator station shall be provided with a smoke control display to allow all fan systems, via a single command, to be placed in the off mode, the zero outside air mode, or the pressurization mode with fully open outside air dampers.

The fan shall be shut down anytime an unsafe temperature exists at a manual reset hard-wired firestat located as required by codes.

5. Fan Fail Alarm. Any time the fan is commanded on and the fan differential pressure switch piped across the fan, or a fan current sensor, does not prove air flow or fan operation, a fan-failed alarm shall be presented to the operator station. This alarm check shall be delayed upon fan start for 10 seconds (adjustable) to give the system time to prove flow prior to creating a false alarm.
6. Minimum Ventilation Control. Anytime the fan runs in the occupied mode, the outside & return air mixing dampers shall open to the outside air to a position required to introduce the minimum outside air required for design occupant ventilation. ***(Include the following sentence if desired)*** Anytime the indoor air quality (IAQ) sensor detects reduced occupant air contaminants, the minimum outside air damper position shall be reduced to 50% of the design maximum to maintain a normal design IAQ.
7. Temperature Control, Occupied Periods. Heating control shall operate with 6 cycles per hour, and cooling control shall operate with 4 cycles per hour unless other parameters are dictated by the equipment manufacturer. If the scheduler commands the fan to stop during periods of electric duct heating, the heater shall be deenergized and the fan shall continue to run for 60 seconds to dissipate the residual heater heat prior to stopping air flow. A staging PID algorithm with heating and cooling anticipation features shall be employed for all staging control. Upon a drop in space temperature below the heating setpoint, the lead duct heater shall be energized, the on-time proportional to the heating load. After the lead heater stage becomes full on, a further increase in the heating load shall cause the lag heating stage to be cycled, the on time proportional to the increasing load. The reverse of this shall happen on a decrease in heating load. Upon a rise in space temperature above the cooling setpoint, the lead compressor/coil shall be energized, the on-time proportional to the cooling load. After the lead cooling stage becomes full on, a further increase in the cooling load shall cause the lag compressor/coil stage to be cycled, the on time proportional to the increasing load. The reverse of this shall happen on a decrease in cooling load.

Anytime the outside air enthalpy is lower than that of indoor air of 75F and 50% humidity, the mixing dampers shall be positioned to full outside air. Anytime both cooling compressors/coils are off in this economizer operational mode and the space cooling load decreases, the mixing dampers shall be modulated to prevent overcooling the space with outside air.

***(Two optional paragraphs for the above paragraph if desired)***

***OA/RA enthalpy comparison changeover:*** Anytime the outside air enthalpy is lower than the return air enthalpy, the mixing dampers shall be positioned to full outside air. Anytime both cooling compressors/coils are off in this economizer operational mode and the space cooling load decreases, the mixing dampers shall be modulated to prevent overcooling the space with outside air.

***OA dry bulb changeover:*** Anytime the outside air temperature is below 71 degrees, the mixing dampers shall be positioned to full outside air. Anytime both cooling compressors/coils are off in this economizer operational mode and the space cooling load decreases, the mixing dampers shall be modulated to prevent overcooling the space with outside air.

If the space temperature drops or rises to either the heating or cooling unoccupied temperature setpoint during unoccupied periods, the system shall start and operate in the heating or cooling mode until the unoccupied temperature setpoints have been satisfied. The same operation shall occur for the standby mode of operation where specified.

8. Discharge Low Limit. If at any time the discharge air drops below the user defined discharge air temperature low limit, an alarm shall be issued and the mixing dampers shall be driven closed to the outside air. As the temperature rises, the dampers shall modulate open to the minimum ventilation position and the alarm shall clear.
9. Miscellaneous. A differential pressure switch piped across each units filter shall alarm the operator station anytime the pressure drop signifies that the filter is dirty.
10. Wall Sensor Module. Wall temperature sensor module shall be located where shown on the plans, and shall include the temperature sensor, the occupied/unoccupied override selection push button with override status LED (where specified), a warmer-cooler setpoint adjustment knob (where specified), and a jack for connecting to the LonTalk communication network. The system owner determines the normal heating and cooling room temperature setpoints for all wall module sensors (such as 73F & 77F). The warmer-cooler adjustment knob on the wall module shall give room occupants the ability to vary these values by an owner determined increment, such as two degrees, by rotating the setpoint knob. Setpoints in use when the room is unoccupied shall not be affected by the setpoint knob.

\*\*\*\*\*

- B. Constant Volume Air Handling Unit, Chilled Water Cooling, Hot Water Heating, with Economizer Enabled from Outside Air Dry Bulb Temperature.

Constant Volume HVAC Unit Controller Software. The constant volume unit controller shall be configurable for air handlers with staged or analog heating and cooling, minimum or modulating economizer outside or mixing damper dampers, and enthalpy or dry bulb economizer changeover. Controller shall comply with LonMark HVAC profile #8030.

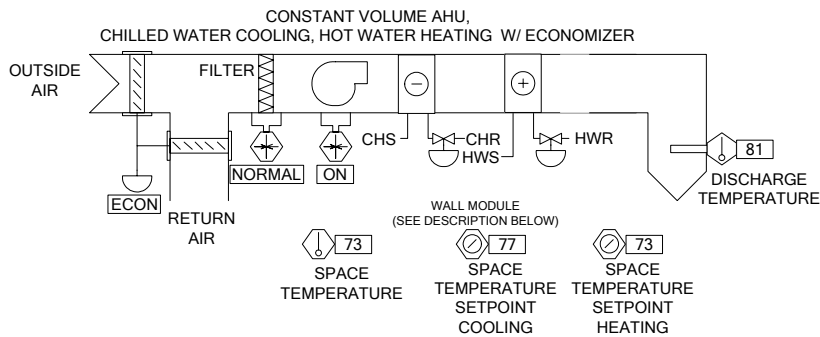

1. Fan Off. Anytime the fan is off, all system heating and cooling shall be off, and the mixing dampers shall be positioned closed to the outside air. Mixing dampers shall spring-return closed to the outside air on power failure.
2. Fan and Mode Control. System fan and heating/cooling temperature setpoints shall normally be placed in the occupied, standby, or unoccupied mode of operation and control via a system scheduler unique seven day schedule. Prior to scheduled occupied periods, the unoccupied temperature setpoint shall be ramped up to the occupied setpoint over a time period proportional to the temperature difference between the room temperature and the occupied temperature setpoint such that at occupancy time the occupied temperature is reached. During unoccupied and standby periods the outside air damper shall be closed and the fan shall remain off until heating or cooling is demanded to satisfy the unoccupied and standby temperature setpoints. The standby mode of operation is for periods of temporary vacancy such as the lunch hour, and shall use owner determined temperature setpoints a degree or two away from the occupied comfort settings.

System shall automatically revert to the proper mode of operation after restoration of power after a power failure. Units shall restart at a random staggered time interval after power restoration.

3. Occupant Schedule Override Control. When any room HVAC system is operating in a mode other than OCCUPIED, each temperature sensor wall module schedule override button shall provide the room occupant with ability to place the system in the occupied mode of operation for 60 (180 default, user programmable) minutes by pressing the module override button. Via the button, the occupant shall also have the ability to cancel the override command, or to place the system in the unoccupied mode when operating in the occupied mode. Via the module LED, the occupant shall have the ability to note the status of the system overrides as being in the override mode, override unoccupied mode, continuously occupied mode via a network command, or in the normal mode of operation (LED off).
4. Smoke Control. The operator station shall be provided with a smoke control display to allow all fan systems, via a single command, to be placed in the off mode, the zero outside air mode, or the pressurization mode with fully open outside air dampers.

The fan shall be shut down anytime an unsafe temperature exists at a manual reset hard-wired firestat located as required by codes.

5. Fan Fail Alarm. Any time the fan is commanded on and the fan differential pressure switch piped across the fan does not prove air flow, a fan-failed alarm shall be presented to the operator station. This alarm check shall be delayed upon fan start for 10 seconds (adjustable) to give the system time to prove flow prior to creating a false alarm.
6. Minimum Ventilation Control. Anytime the fan runs in the occupied mode, the outside & return air mixing dampers shall open to the outside air to a position required to introduce the minimum outside air required for design occupant ventilation. ***(Include the following sentence if desired)*** Anytime the indoor air quality (IAQ) sensor detects reduced occupant air contaminants, the minimum outside air damper position shall be reduced to 50% of the design maximum to maintain a normal design IAQ.
7. Temperature Control, Occupied Periods. During occupied periods of operation, separate PID algorithms shall modulate the heating or cooling valve to maintain temperatures at the occupied setpoints.

Anytime the outside air enthalpy is lower than that of indoor air of 75F and 50% humidity, the mixing dampers shall be positioned to full outside air. Anytime the chilled water valve is closed in this economizer operational mode and the space cooling load decreases, the mixing dampers shall be modulated to prevent overcooling the space with outside air.

***(Two optional paragraphs for the above paragraph if desired)***

***OA/RA enthalpy comparison changeover:*** Anytime the outside air enthalpy is lower than the return air enthalpy, the mixing dampers shall be positioned to full outside air. Anytime the chilled water valve is closed in this economizer operational mode and the space cooling load decreases, the mixing dampers shall be modulated to prevent overcooling the space with outside air.

***OA dry bulb changeover:*** Anytime the outside air temperature is below 71 degrees, the mixing dampers shall be positioned to full outside air. Anytime the chilled water valve is closed in this economizer operational mode and the space cooling load decreases, the mixing dampers shall be modulated to prevent overcooling the space with outside air.

8. Temperature Control, Unoccupied Periods. If the AHU-X space temperature drops or rises to either the heating or cooling unoccupied temperature setpoint during unoccupied periods, all fans shall start and operate to maintain the unoccupied temperature setpoints. When the AHU-X space temperature is satisfied, the fans shall stop. The same operation shall occur for the standby mode of operation where specified.
9. Discharge Low Limit. If at any time the discharge air drops below the user defined discharge air temperature low limit, an alarm shall be issued and the mixing dampers shall be driven closed to the outside air. As the temperature rises, the dampers shall modulate open to the minimum ventilation position and the alarm shall clear.
10. Plant Commands. Anytime any hot water valve opens, the hot water pump shall be started and the heating plant shall be enabled. Anytime any chilled water valve opens, the chilled water pump shall be started and the cooling plant shall be enabled.
11. Miscellaneous. A differential pressure switch piped across each units filter and shall alarm the operator station anytime the pressure drop signifies that the filter is dirty.

12. Wall Sensor Module. Wall temperature sensor module shall be located where shown on the plans, and shall include the temperature sensor, the occupied/unoccupied override selection push button with override status LED (where specified), a warmer-cooler setpoint adjustment knob (where specified), and a jack for connecting to the LonTalk communication network. The system owner determines the normal heating and cooling room temperature setpoints for all wall module sensors (such as 73F & 77F). The warmer-cooler adjustment knob on the wall module shall give room occupants the ability to vary these values by an owner determined increment, such as two degrees, by rotating the setpoint knob. Setpoints in use when the room is unoccupied shall not be affected by the setpoint knob.

\*\*\*\*\*

C. Unit Ventilator, One Stage DX, Hot Water Heating, Single Speed Fan, with Economizer.

Unit Ventilator Controllers. The unit ventilator controllers shall be configurable for ASHRAE Cycles I, II, and III; chilled water or DX cooling; hot water, steam or electric heating; economizer or fixed minimum outside air; and face and bypass dampers. Controller shall comply with LonMark HVAC profile #8080.

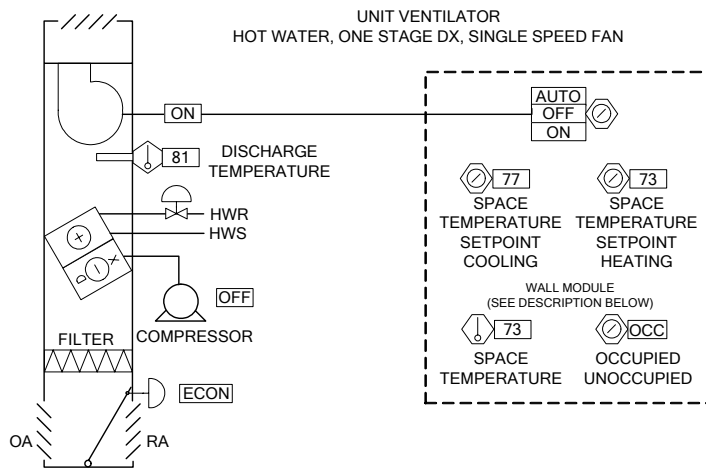

1. Fan Off. Anytime the fan is off, all system heating and cooling shall be off, and the mixing dampers shall be positioned closed to the outside air. Mixing dampers shall spring-return closed to the outside air on power failure.
2. Fan and Mode Control. System fan and heating/cooling temperature setpoints shall normally be placed in the occupied, standby, or unoccupied mode of operation and control via a system

scheduler unique seven day schedule. Prior to scheduled occupied periods, the unoccupied temperature setpoint shall be ramped up to the occupied setpoint over a time period proportional to the temperature difference between the room temperature and the occupied temperature setpoint such that at occupancy time the occupied temperature is reached. During unoccupied and standby periods the outside air damper shall be closed and the fan shall remain off until heating or cooling is demanded to satisfy the unoccupied and standby temperature setpoints. The standby mode of operation is for periods of temporary vacancy such as the lunch hour, and shall use owner determined temperature setpoints a degree or two away from the occupied comfort settings.

System shall automatically revert to the proper mode of operation after restoration of power after a power failure. Units shall restart at a random staggered time interval.

3. Occupant Schedule Override Control. When any room HVAC system is operating in a mode other than OCCUPIED, each temperature sensor wall module schedule override button shall provide the room occupant with ability to place the system in the occupied mode of operation for 60 (180 default, user programmable) minutes by pressing the module override button. Via the button, the occupant shall also have the ability to cancel the override command, or to place the system in the unoccupied mode when operating in the occupied mode. Via the module LED, the occupant shall have the ability to note the status of the system overrides as being in the override mode, override unoccupied mode, continuously occupied mode via a network command, or in the normal mode of operation (LED off).
4. Smoke Control. The operator station shall be provided with a smoke control display to allow all fan systems, via a single command, to be placed in the off mode, the zero outside air mode, or the pressurization mode with fully open outside air dampers.
5. Minimum Ventilation Control. Anytime the fan runs in the occupied mode, the outside & return air mixing dampers shall open to the outside air to a position required to introduce the minimum outside air required for design occupant ventilation. ***(Include the following sentence if desired)*** Anytime the indoor air quality (IAQ) sensor detects reduced occupant air contaminants, the minimum outside air damper position shall be reduced to 50% of the design maximum to maintain a normal design IAQ.
6. Temperature Control. Occupied Periods. Each AHU shall have adjustable occupied, standby, and unoccupied heating and cooling setpoints. During occupied periods of operation, separate PID algorithms shall modulate the heating valve or cycle the compressor to maintain temperatures within the occupied setpoints. Although adjustable, the initial compressor control shall be set for 3 cycles per hour and 5.5 minutes minimum on and off times. The cooling PID algorithm shall have cooling anticipation to minimize temperature offset.

Anytime the outside air enthalpy is lower than that of indoor air of 75F and 50% humidity, the mixing dampers shall be positioned to full outside air. Anytime the compressor is off in this economizer operational mode and the space cooling load decreases, the mixing dampers shall be modulated to prevent overcooling the space with outside air.

***(Two optional paragraphs for the above paragraph if desired)***

***OA/RA enthalpy comparison changeover:*** Anytime the outside air enthalpy is lower than the return air enthalpy, the mixing dampers shall be positioned to full outside air. Anytime the

*compressor is off in this economizer operational mode and the space cooling load decreases, the mixing dampers shall be modulated to prevent overcooling the space with outside air.*

***OA dry bulb changeover:*** *Anytime the outside air temperature is below 71 degrees, the mixing dampers shall be positioned to full outside air. Anytime the compressor is off in this economizer operational mode and the space cooling load decreases, the mixing dampers shall be modulated to prevent overcooling the space with outside air.*

If the space temperature rises to the cooling unoccupied temperature setpoint during unoccupied periods, the system shall start and operate in the cooling mode until the unoccupied temperature setpoints have been satisfied. The outside air damper shall remain closed during unoccupied periods of operation. The same operation shall occur for the standby modes of operation where specified.

If the AHU-X space temperature drops to the heating unoccupied temperature setpoint during unoccupied periods, the hot water system shall start and all fans shall start and operate to maintain the unoccupied temperature setpoints. When the AHU-X space temperature rises, the fans shall stop. The outside air damper shall remain closed during unoccupied periods of operation. Each unit ventilator shall cycle its respective fans and compressors if required to maintain their respective unoccupied cooling setpoints. The same operation shall occur for the standby modes of operation where specified.

Anytime any hot water valve opens, the hot water pump shall be started and the heating plant shall be enabled.

7. Where ASHRAE cycles I, II, or III are used, the discharge air temperature sensor shall prevent the air from dropping below a user defined low limit value.
8. Wall Sensor Module. Wall temperature sensor module shall be located where shown on the plans, and shall include the temperature sensor, the occupied/unoccupied override selection push button with override status LED (where specified), a warmer-cooler setpoint adjustment knob (where specified), and a jack for connecting to the LonTalk communication network. The system owner determines the normal heating and cooling room temperature setpoints for all wall module sensors (such as 73F & 77F). The warmer-cooler adjustment knob on the wall module shall give room occupants the ability to vary these values by an owner determined increment, such as two degrees, by rotating the setpoint knob. Setpoints in use when the room is unoccupied shall not be affected by the setpoint knob.

\*\*\*\*\*

D. Fan Coil Unit, Chilled Water Cooling, Hot Water Heating, with Wall Module Fan Switch

Fan Coil Unit Controller Software. The fan coil unit controller shall be configurable for staged or analog heating and cooling. Controller shall comply with LonMark HVAC profile #8020.

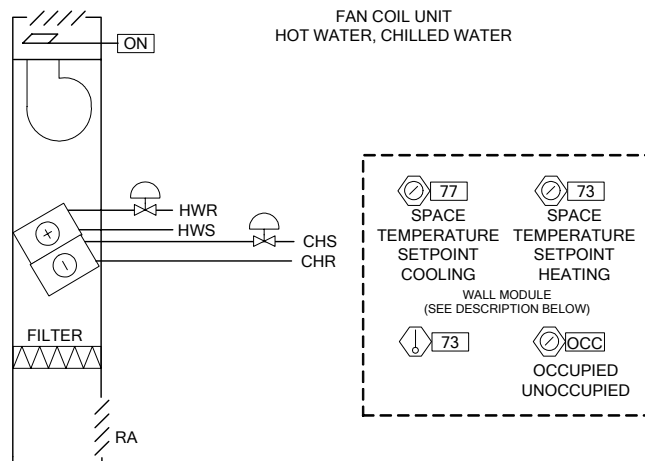

1. Fan On-Off. The fan coil unit shall be controlled via its wall module mounted on-off switch. Anytime the fan is off, all system heating and cooling shall be off.
2. Fan and Mode Control. System fan and heating/cooling temperature setpoints shall normally be placed in the occupied, standby, or unoccupied mode of operation and control via a system scheduler unique seven day schedule. Prior to scheduled occupied periods, the unoccupied temperature setpoint shall be ramped up to the occupied setpoint over a time period proportional to the temperature difference between the room temperature and the occupied temperature setpoint such that at occupancy time the occupied temperature is reached. During unoccupied and standby periods the fan shall remain off until heating or cooling is demanded to satisfy the unoccupied and standby temperature setpoints. The standby mode of operation is for periods of temporary vacancy such as the lunch hour, and shall use owner determined temperature setpoints a degree or two away from the occupied comfort settings.

System shall automatically revert to the proper mode of operation after restoration of power after a power failure.

3. Occupant Schedule Override Control. When any room HVAC system is operating in a mode other than OCCUPIED, each temperature sensor wall module schedule override button shall provide the room occupant with ability to place the system in the occupied mode of operation for 60 (180 default, user programmable) minutes by pressing the module override button. Via the button, the occupant shall also have the ability to cancel the override command, or to place the system in the unoccupied mode when operating in the occupied mode. Via the module LED, the occupant shall have the ability to note the status of the system overrides as being in the override mode, override unoccupied mode, continuously occupied mode via a network command, or in the normal mode of operation (LED off).
4. Temperature Control, Occupied Periods. During occupied periods of operation, separate PID algorithms shall modulate the heating or cooling valve to maintain temperatures at the occupied setpoints.

5. Temperature Control, Unoccupied Periods. If the FCU-X space temperature drops or rises to either the heating or cooling unoccupied temperature setpoint during unoccupied periods, all fans shall start and operate to maintain the unoccupied temperature setpoints. When the FCU-X space temperature is satisfied, the fans shall stop. The same operation shall occur for the standby mode of operation where specified.
6. Plant Commands. Anytime any hot water valve opens, the hot water pump shall be started and the heating plant shall be enabled. Anytime any chilled water valve opens, the chilled water pump shall be started and the cooling plant shall be enabled.
7. Wall Sensor Module. Wall temperature sensor module shall be located where shown on the plans, and shall include the temperature sensor, the occupied/unoccupied override selection push button with override status LED (where specified), a warmer-cooler setpoint adjustment knob (where specified), and a jack for connecting to the LonTalk communication network. The system owner determines the normal heating and cooling room temperature setpoints for all wall module sensors (such as 73F & 77F). The warmer-cooler adjustment knob on the wall module shall give room occupants the ability to vary these values by an owner determined increment, such as two degrees, by rotating the setpoint knob. Setpoints in use when the room is unoccupied shall not be affected by the setpoint knob. During occupied periods of operation, the fan shall be controlled by the wall module fan switch.

\*\*\*\*\*

- E. Fan Coil Unit, Chilled Water Cooling, Hot Water Heating, with Manual Fan Coil Unit Mounted Fan Switch.

Fan Coil Unit Controller Software. The fan coil unit controller shall be configurable for staged or analog heating and cooling. Controller shall comply with LonMark HVAC profile #8020.

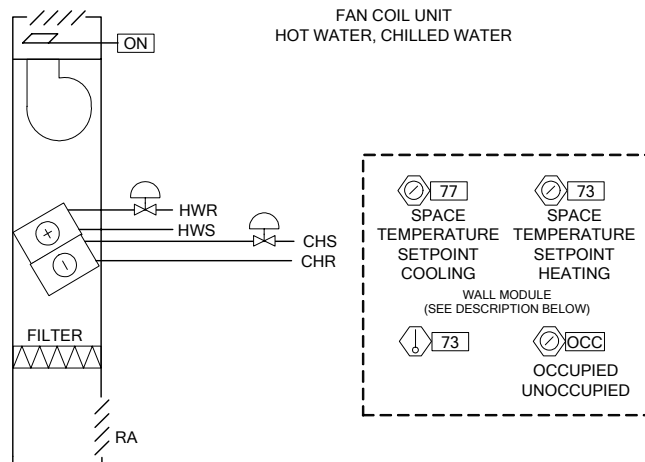

1. Fan On-Off. During occupied periods, the fan shall be controlled manually by the unit-mounted fan control switch. Anytime the fan is off as detected by an air flow switch, all system heating and cooling shall be off and valves shall close.
2. Mode Control. System heating/cooling temperature setpoints shall normally be placed in the occupied, standby, or unoccupied mode of operation and control via a system scheduler unique seven day schedule. Prior to scheduled occupied periods, the unoccupied temperature setpoint shall be ramped up to the occupied setpoint over a time period proportional to the temperature difference between the room temperature and the occupied temperature setpoint such that at occupancy time the occupied temperature is reached. The standby mode of operation is for periods of temporary vacancy such as the lunch hour, and shall use owner determined temperature setpoints a degree or two away from the occupied comfort settings.

System shall automatically revert to the proper mode of operation after restoration of power after a power failure.

3. Occupant Schedule Override Control. When any room HVAC system is operating in a mode other than OCCUPIED, each temperature sensor wall module schedule override button shall provide the room occupant with ability to place the system in the occupied mode of operation for 60 (180 default, user programmable) minutes by pressing the module override button. Via the button, the occupant shall also have the ability to cancel the override command, or to place the system in the unoccupied mode when operating in the occupied mode. Via the module LED, the occupant shall have the ability to note the status of the system overrides as being in the override mode, override unoccupied mode, continuously occupied mode via a network command, or in the normal mode of operation (LED off).
4. Temperature Control, Occupied Periods. During occupied periods of operation, separate PID algorithms shall modulate the heating or cooling valve to maintain temperatures at the occupied setpoints.
5. Temperature Control, Unoccupied Periods. If the FCU-X space temperature drops or rises to either the heating or cooling unoccupied temperature setpoint during unoccupied periods, all fans shall start and operate to maintain the unoccupied temperature setpoints. When the FCU-X space temperature is satisfied, the fans shall stop. The same operation shall occur for the standby mode of operation where specified.
6. Plant Commands. Anytime any hot water valve opens, the hot water pump shall be started and the heating plant shall be enabled. Anytime any chilled water valve opens, the chilled water pump shall be started and the cooling plant shall be enabled.
8. Wall Sensor Module. Wall temperature sensor module shall be located where shown on the plans, and shall include the temperature sensor, the occupied/unoccupied override selection push button with override status LED (where specified), a warmer-cooler setpoint adjustment knob (where specified), and a jack for connecting to the LonTalk communication network. The system owner determines the normal heating and cooling room temperature setpoints for all wall module sensors (such as 73F & 77F). The warmer-cooler adjustment knob on the wall module shall give room occupants the ability to vary these values by an owner determined increment, such as two degrees, by rotating the setpoint knob. Setpoints in use when the room is unoccupied shall not be affected by the setpoint knob.

\*\*\*\*\*

F. Chilled Ceiling Unit with Hot Water Radiation

Chilled Ceiling/Hot Water Radiation Controllers. The room temperature controller shall be LonMark based suitable for chilled water cooling and hot water, steam or electric heating. Controller shall comply with LonMark HVAC profile # 8020.

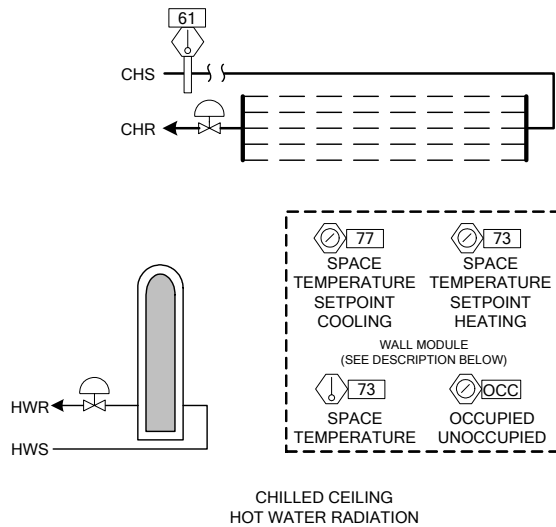

1. Room Mode Control. System heating/cooling temperature setpoints shall normally be placed in the occupied, standby, or unoccupied mode of operation and control via a system scheduler unique seven day schedule. Prior to scheduled occupied periods, the unoccupied temperature setpoint shall be ramped up to the occupied setpoint over a time period proportional to the temperature difference between the room temperature and the occupied temperature setpoint such that at occupancy time the occupied temperature is reached. The standby mode of operation is for periods of temporary vacancy such as the lunch hour, and shall use owner determined temperature setpoints a degree or two away from the occupied comfort settings.

System shall automatically revert to the proper mode of operation after restoration of power after a power failure.

2. Occupant Schedule Override Control. When any room system is operating in a mode other than OCCUPIED, each specified temperature sensor wall module schedule override button shall

provide the room occupant with ability to place the system in the occupied mode of operation for 60 (180 default, user programmable) minutes by pressing the module override button. Via the button, the occupant shall also have the ability to cancel the override command, or to place the system in the unoccupied mode when operating in the occupied mode. Via the module LED, the occupant shall have the ability to note the status of the system overrides as being in the override mode, override unoccupied mode, continuously occupied mode via a network command, or in the normal mode of operation (LED off).

3. Temperature Control, Occupied Periods. During occupied periods of operation, separate PID algorithms shall modulate the heating or cooling valve to maintain temperatures at the occupied setpoints.
4. Temperature Control, Unoccupied Periods. If the ROOM-X space temperature drops or rises to either the heating or cooling unoccupied temperature setpoint during unoccupied periods, the appropriate heating or cooling plant shall start and operate to maintain the unoccupied temperature setpoints. When the ROOM-X space temperature is satisfied, plant shall stop. The same operation shall occur for the standby mode of operation where specified.
5. Wall Controller Module. Wall temperature sensor module shall be located where shown on the plans, and shall include the room controller, the temperature sensor, the occupied/unoccupied override selection push button with override status LED where specified, a warmer-cooler setpoint adjustment knob where specified, and a jack for connecting to the LonWorks communication network. The system owner determines the normal heating and cooling room temperature setpoints for all wall module sensors (such as 73F & 77F). The warmer-cooler adjustment knob on the wall module shall give room occupants the ability to vary these values by an owner determined increment, such as two degrees, by rotating the setpoint knob. Setpoints in use when the room is unoccupied shall not be affected by the setpoint knob.
6. Dewpoint Control. If at any time the ceiling panel chilled water temperature drops below the owner determined panel dewpoint temperature, an alarm shall be issued to the operator station and all ceiling panel valves shall close until the chilled water temperature recovers.

\*\*\*\*\*

G. VAV Box, Cooling Only, Pressure Independent

VAV Box Software. The VAV box controller shall be LonMark based suitable pressure dependent and pressure independent control. Controller shall comply with LonMark HVAC profile # 8010.

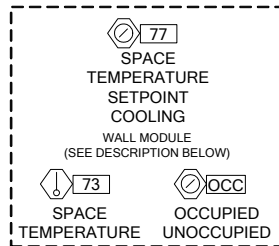
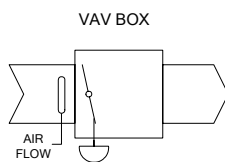

1. Temperature Control. Zone temperature cooling setpoint shall normally be placed in the occupied, standby, or unoccupied mode of operation and control via a system scheduler unique seven day schedule. Prior to scheduled occupied periods, the unoccupied temperature setpoint shall be ramped down to the occupied setpoint over a time period proportional to the temperature difference between the room temperature and the occupied temperature setpoint such that at occupancy time the occupied temperature is reached. During unoccupied and standby periods the unoccupied and standby temperature setpoints shall be maintained. The standby mode of operation is for periods of temporary vacancy such as the lunch hour, and shall use owner determined temperature setpoints a degree or two away from the occupied comfort settings.

VAV box controls shall be enabled anytime the respective VAV AHU fan operates. Each VAV box shall have unique design minimum and maximum primary air cfm setpoints. As the cooling load varies a PID algorithm shall reset the box cfm setpoint between these min and max values to maintain the setpoint. An AIA algorithm shall modulate the box damper to maintain the cfm setpoint.

The BMCS operator shall have displays of the space temperature, the primary air cfm, and the box damper position. The operator shall have displays and modification ability of the three temperature setpoints and the two cfm setpoints.

2. Occupant Schedule Override Control. When any room HVAC system is operating in a mode other than OCCUPIED, each temperature sensor wall module shall provide the room occupant with ability to place the system in the occupied mode of operation for 60 (180 default, user programmable) minutes by pressing the wall module override button. Via the button, the occupant shall also have the ability to cancel the override command, or to place the system in the unoccupied mode when operating in the occupied mode. Via the module LED, the occupant shall have the ability to note the status of the system overrides as being in the override mode, override unoccupied mode, continuously occupied mode via a network command, or in the normal mode of operation (LED off).
3. Wall Sensor Module. Wall temperature sensor module shall be located where shown on the plans, and shall include the temperature sensor, the occupied/unoccupied override selection push button with override status LED (where specified), a warmer-cooler setpoint adjustment knob (where specified), and a jack for connecting to the LonWorks communication network (***Except for Low Cost models***). The system owner determines the normal heating and cooling room temperature setpoints for all wall module sensors (such as 73F & 77F). The warmer-cooler adjustment knob on the wall module shall give room occupants the ability to vary these values by an owner determined increment, such as two degrees, by rotating the setpoint knob. Setpoints in use when the room is unoccupied shall not be affected by the setpoint knob.

\*\*\*\*\*

#### H. VAV Box, Cooling & 2-Stage Heat, Pressure Independent

VAV Box Software. The VAV box controller shall be LonMark based suitable pressure dependent and pressure independent control and staged electric heat. Controller shall comply with LonMark HVAC profile # 8010.

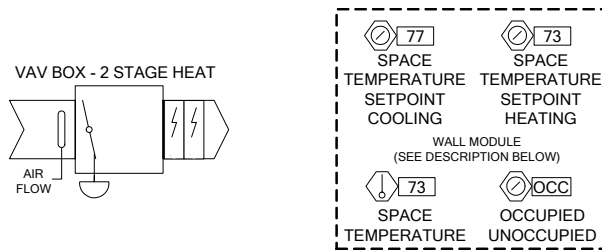

1. Temperature Control. Zone temperature setpoints shall normally be placed in the occupied, standby, or unoccupied mode of operation and control via a system scheduler unique seven day schedule. Prior to scheduled occupied periods, the unoccupied temperature setpoint shall be ramped up or down to the occupied setpoint over a time period proportional to the temperature difference between the room temperature and the occupied temperature setpoint such that at occupancy time the occupied temperature is reached. During unoccupied and standby periods the unoccupied and standby heating and cooling temperature setpoints shall be maintained. The standby mode of operation is for periods of temporary vacancy such as the lunch hour, and shall use owner determined temperature setpoints a degree or two away from the occupied comfort settings.

VAV box controls shall be enabled anytime the respective VAV AHU fan operates. Each VAV box shall have unique design minimum, reheat, and maximum primary air cfm setpoints. As the cooling load varies a PID algorithm shall reset the box cfm setpoint between these min and max values to maintain the cooling setpoint. An AIA algorithm shall modulate the box damper to maintain the cfm setpoint. (An AIA is an adaptive algorithm designed specially for the application)

As the zone temperature drops to the heating setpoint, the box shall maintain the reheat cfm setpoint and cycle the duct heaters to maintain the setpoint. The heating algorithm shall be PID with anticipation characteristics to minimize room temperature overshoot.

The BMCS operator shall have displays of the space temperature, the primary air cfm, the box damper position, and the duct heater status'. The operator shall have displays and modification ability of the six temperature setpoints and the three cfm setpoints.

2. Occupant Schedule Override Control. When any room HVAC system is operating in a mode other than OCCUPIED, each temperature sensor wall module shall provide the room occupant with ability to place the system in the occupied mode of operation for 60 (180 default, user programmable) minutes by pressing the wall module override button. Via the button, the occupant shall also have the ability to cancel the override command, or to place the system in the unoccupied mode when operating in the occupied mode. Via the module LED, the occupant shall have the ability to note the status of the system overrides as being in the override mode, override

unoccupied mode, continuously occupied mode via a network command, or in the normal mode of operation (LED off).

3. Wall Sensor Module. Wall temperature sensor module shall be located where shown on the plans, and shall include the temperature sensor, the occupied/unoccupied override selection push button with override status LED (where specified), a warmer-cooler setpoint adjustment knob (where specified), and a jack for connecting to the LonWorks communication network (*Except for Low Cost models*). The system owner determines the normal heating and cooling room temperature setpoints for all wall module sensors (such as 73F & 77F). The warmer-cooler adjustment knob on the wall module shall give room occupants the ability to vary these values by an owner determined increment, such as two degrees, by rotating the setpoint knob. Setpoints in use when the room is unoccupied shall not be affected by the setpoint knob.

\*\*\*\*\*

I. VAV Box, Cooling & Hot Water Heat, Pressure Independent

VAV Box Software. The VAV box controller shall be LonMark based suitable pressure dependent and pressure independent control with modulating heating and cooling. Controller shall comply with LonMark HVAC profile # 8010.

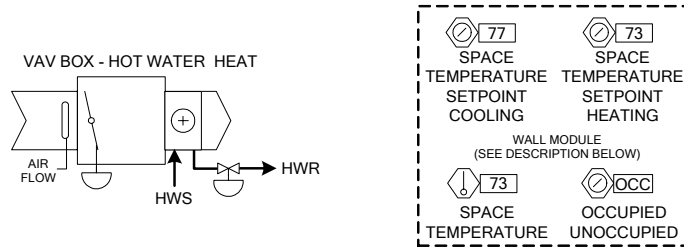

1. Temperature Control. Zone temperature setpoints shall normally be placed in the occupied, standby, or unoccupied mode of operation and control via a system scheduler unique seven day schedule. Prior to scheduled occupied periods, the unoccupied temperature setpoint shall be ramped up or down to the occupied setpoint over a time period proportional to the temperature difference between the room temperature and the occupied temperature setpoint such that at occupancy time the occupied temperature is reached. During unoccupied and standby periods the unoccupied and standby heating and cooling temperature setpoints shall be maintained. The standby mode of operation is for periods of temporary vacancy such as the lunch hour, and shall use owner determined temperature setpoints a degree or two away from the occupied comfort settings.

VAV box controls shall be enabled anytime the respective VAV AHU fan operates. Each VAV box shall have unique design minimum and maximum primary air cfm setpoints. As the cooling load varies a PID algorithm shall reset the box cfm setpoint between these min and max values to

maintain the setpoint. An AIA algorithm shall modulate the box damper to maintain the cfm setpoint.

As the zone temperature drops to the heating setpoint, the box shall maintain the minimum cfm setpoint and modulate the hot water valve via a PID algorithm to maintain the heating setpoint.

The BMCS operator shall have displays of the space temperature, the primary air cfm, the box damper position, and the hot water valve position. The operator shall have displays and modification ability of the six temperature setpoints and the two cfm setpoints.

2. Occupant Schedule Override Control. When any room HVAC system is operating in a mode other than OCCUPIED, each temperature sensor wall module shall provide the room occupant with ability to place the system in the occupied mode of operation for 60 (180 default, user programmable) minutes by pressing the wall module override button. Via the button, the occupant shall also have the ability to cancel the override command, or to place the system in the unoccupied mode when operating in the occupied mode. Via the module LED, the occupant shall have the ability to note the status of the system overrides as being in the override mode, override unoccupied mode, continuously occupied mode via a network command, or in the normal mode of operation (LED off).
3. Wall Sensor Module. Wall temperature sensor module shall be located where shown on the plans, and shall include the temperature sensor, the occupied/unoccupied override selection push button with override status LED (where specified), a warmer-cooler setpoint adjustment knob (where specified), and a jack for connecting to the LonWorks communication network (*Except for Low Cost models*). The system owner determines the normal heating and cooling room temperature setpoints for all wall module sensors (such as 73F & 77F). The warmer-cooler adjustment knob on the wall module shall give room occupants the ability to vary these values by an owner determined increment, such as two degrees, by rotating the setpoint knob. Setpoints in use when the room is unoccupied shall not be affected by the setpoint knob.

**PART 6**

\*\*\*\*\*

J. VAV Box, Cooling and Hot Water Heat, Parallel Fan, & Pressure Independent

VAV Box Software. The VAV box controller shall be LonMark based suitable pressure dependent and pressure independent control, hot water heat, and parallel fan. Controller shall comply with LonMark HVAC profile # 8010.

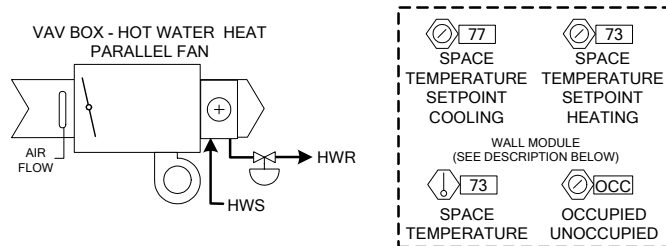

1. Temperature Control. Zone temperature setpoints shall normally be placed in the occupied, standby, or unoccupied mode of operation and control via a system scheduler unique seven day schedule. Prior to scheduled occupied periods, the unoccupied temperature setpoint shall be ramped up or down to the occupied setpoint over a time period proportional to the temperature difference between the room temperature and the occupied temperature setpoint such that at occupancy time the occupied temperature is reached. During unoccupied and standby periods the unoccupied and standby heating and cooling temperature setpoints shall be maintained. The standby mode of operation is for periods of temporary vacancy such as the lunch hour, and shall use owner determined temperature setpoints a degree or two away from the occupied comfort settings.

VAV box controls shall be enabled anytime the respective VAV AHU fan operates. Each VAV box shall have unique design minimum and maximum primary air cfm setpoints. As the cooling load varies a PID algorithm shall reset the box cfm setpoint between these min and max values to maintain the setpoint. An AIA algorithm shall modulate the box damper to maintain the cfm setpoint.

As the zone temperature drops to the heating setpoint, the box shall maintain the minimum cfm setpoint for the primary air and start the parallel fan for the first stage of heating with the warm plenum air. As the heating load increases, the hot water valve shall be modulated open via a PID algorithm to maintain the heating setpoint.

The BMCS operator shall have displays of the space temperature, the primary air cfm, the box damper position, the parallel fan status, and the hot water valve position. The operator shall have displays and modification ability of the six temperature setpoints and the two cfm setpoints.

2. Occupant Schedule Override Control. When any room HVAC system is operating in a mode other than OCCUPIED, each temperature sensor wall module shall provide the room occupant with ability to place the system in the occupied mode of operation for 60 (180 default, user programmable) minutes by pressing the wall module override button. Via the button, the occupant shall also have the ability to cancel the override command, or to place the system in the unoccupied mode when operating in the occupied mode. Via the module LED, the occupant shall have the ability to note the status of the system overrides as being in the override mode, override unoccupied mode, continuously occupied mode via a network command, or in the normal mode of operation (LED off).

3. Wall Sensor Module. Wall temperature sensor module shall be located where shown on the plans, and shall include the temperature sensor, the occupied/unoccupied override selection push button with override status LED (where specified), a warmer-cooler setpoint adjustment knob (where specified), and a jack for connecting to the LonWorks communication network (*Except for Low Cost models*). The system owner determines the normal heating and cooling room temperature setpoints for all wall module sensors (such as 73F & 77F). The warmer-cooler adjustment knob on the wall module shall give room occupants the ability to vary these values by an owner determined increment, such as two degrees, by rotating the setpoint knob. Setpoints in use when the room is unoccupied shall not be affected by the setpoint knob.

**PART 7**

\*\*\*\*\*

**K. VAV Box, Cooling, Hot Water Heat, Series Fan, Pressure Independent**

VAV Box Software. The VAV box controller shall be LonMark based suitable pressure dependent and pressure independent control with hot water heat and series fan. Controller shall comply with LonMark HVAC profile # 8010.

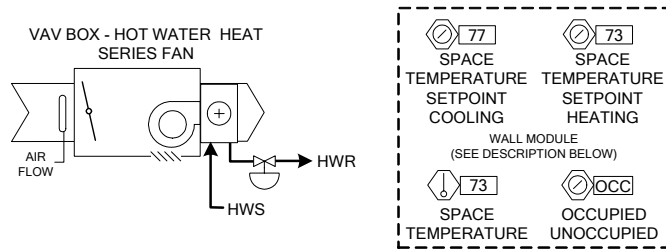

1. Temperature Control. Zone temperature setpoints shall normally be placed in the occupied, standby, or unoccupied mode of operation and control via a system scheduler unique seven day schedule. Prior to scheduled occupied periods, the unoccupied temperature setpoint shall be ramped up or down to the occupied setpoint over a time period proportional to the temperature difference between the room temperature and the occupied temperature setpoint such that at occupancy time the occupied temperature is reached. During unoccupied and standby periods the unoccupied and standby heating and cooling temperature setpoints shall be maintained. The standby mode of operation is for periods of temporary vacancy such as the lunch hour, and shall use owner determined temperature setpoints a degree or two away from the occupied comfort settings.

VAV box controls shall be enabled anytime the respective VAV AHU fan operates. Each VAV box shall have unique design minimum and maximum primary air cfm setpoints. As the cooling load varies a PID algorithm shall reset the box cfm setpoint between these min and max values to maintain the setpoint. An AIA algorithm shall modulate the box damper to maintain the cfm setpoint.

As the zone temperature drops to the heating setpoint, the box shall maintain the minimum cfm setpoint for the primary air and the hot water valve shall be modulated open via a PID algorithm to maintain the heating setpoint.

The BMCS operator shall have displays of the space temperature, the primary air cfm, the box damper position, the series fan status, and the hot water valve position. The operator shall have displays and modification ability of the six temperature setpoints and the two cfm setpoints.

2. Occupant Schedule Override Control. When any room HVAC system is operating in a mode other than OCCUPIED, each temperature sensor wall module shall provide the room occupant with ability to place the system in the occupied mode of operation for 60 (180 default, user programmable) minutes by pressing the wall module override button. Via the button, the occupant shall also have the ability to cancel the override command, or to place the system in the unoccupied mode when operating in the occupied mode. Via the module LED, the occupant shall have the ability to note the status of the system overrides as being in the override mode, override unoccupied mode, continuously occupied mode via a network command, or in the normal mode of operation (LED off).
3. Wall Sensor Module. Wall temperature sensor module shall be located where shown on the plans, and shall include the temperature sensor, the occupied/unoccupied override selection push button with override status LED (where specified), a warmer-cooler setpoint adjustment knob (where specified), and a jack for connecting to the LonWorks communication network (*Except for Low Cost models*). The system owner determines the normal heating and cooling room temperature setpoints for all wall module sensors (such as 73F & 77F). The warmer-cooler adjustment knob on the wall module shall give room occupants the ability to vary these values by an owner determined increment, such as two degrees, by rotating the setpoint knob. Setpoints in use when the room is unoccupied shall not be affected by the setpoint knob.

\*\*\*\*\*

**Optional Paragraphs: If analog filter monitoring is desired, substitute all filter switch sequences with the following:** A differential pressure sensor shall be piped across each units filter. When assigned dirty filter analog alarm limits are exceeded, the operator station shall be alarmed.

**If freezestat fan shutdown is required for water system protection, add the following:** Anytime the mixed air temperature drops below the limited fill low temperature limit switch, the fan shall stop and the mixing dampers shall close fully to the outside air.

**If demand control is desired, insert the following paragraph:** Demand Limit Control (DLC). The system shall monitor the building electrical power demand and control specified electrical loads in three categories, off continuous, rotating loads off, and last resort loads.

Off continuous loads shall be shut down for the excessive demand duration, and restored after the excess is over.

Rotating loads shall be provided with unique minimum and maximum demand reduction times, and minimum on-times. In addition to shedding electrical loads, comfort control setpoints shall be assignable to the DLC program shall be assignable to be “bumped” up or down a specified temperature value to reduce heating and cooling energy. The setpoint shall be immediately bumped for energy reduction, but at the end of the demand reduction cycle, the setpoint restoration shall be

slowly ramped back to the comfort settings over a time period to prevent bumping back into the high demand state.

The DLC program shall also maintain an Energy History Log for the previous 35 days including the energy consumed (kWh), the peak load (kW), time of peak load, and the degree days.